

*Customer Register*  
**Fordson**

TRADE MARK

**TRACTOR  
MANUAL**

**Ford Motor Company**  
Detroit, Michigan

**Fordson**  
TRADE MARK  
**TRACTOR  
MANUAL**

*Ford Motor Company*  
Detroit, Michigan

Copyright 1923  
FORD MOTOR CO.  
Detroit, Michigan, U. S. A.

## Foreword

**W**HILE mechanical knowledge or experience is not required to operate the Fordson Tractor, it is very desirable that the operator should understand his Tractor. A thorough knowledge of the construction and function of each part is neither a difficult nor lengthy task. With such knowledge, the operator is in position to maintain his Tractor economically, prolong its usefulness, and if trouble occurs is in position to immediately overcome it.

The simplicity of Fordson construction is readily understood and with study it is easy to keep the Tractor in proper mechanical adjustment and repair.

In order that a quick and comprehensive understanding of the Fordson Tractor, as well as the mechanical adjustment of it may be had, this Manual is prepared as an authentic guide.

## Important Instructions for Operators

1. The importance of correct lubrication cannot be too strongly impressed on tractor drivers. The proper grades of oil must be used in the motor and transmission. The oil should be maintained at the proper level at all times and changed frequently. Keep strainers in breather pipe and oil filler in good condition. Clean oil will protect the motor bearings and cut down spark plug trouble.
2. The worst abuse that can be given the Tractor is by racing the motor. Drivers must avoid this at all times. The proper speed to run the motor is 1000 revolutions per minute. This will give the Tractor the correct working speeds as given in Answer No. 20. When the motor is idling cut the speed down as low as possible and retard spark (spark lever down). When starting, do not speed the motor to heat up the vaporizer quickly. This is destructive to the Tractor and will not accomplish your purpose.
3. It is very important that the air washer be properly filled with water at all times. (Note instructions given on page 25.) If it is not kept clean and filled, dirt will be drawn into the cylinders, resulting in premature wearing of all the motor parts and loss of power.
4. The Drawbar Cap (see Plate No. 5) is provided for your convenience in hitching. Always hitch to this Drawbar Cap. Do not hitch a chain or rope around the rear axle housing under any circumstances. When pulling a heavy load—or in case the Tractor becomes mired—be sure to keep your foot on the clutch pedal. Do not race the motor or let the clutch in suddenly as this might lift the front end of the Tractor off the ground. Should this happen, release the clutch immediately—this will bring the front wheels back to the ground at once. If the Tractor should become mired, always pull out in low gear. Do not attempt to pull tree stumps or do any similar work that might bring the Tractor to a sudden stop.
5. Do not attempt to engage or disengage gears until clutch pedal has been pushed down all the way, nor while the tractor is in motion. When changing the gears, if the clutch is not entirely disengaged the teeth on the gears will not mesh readily, and there is danger of breaking off the edge of the teeth so that in time they will not remain in mesh. Always reduce speed of motor when shifting gears.
6. Do not run the Tractor down hill with the gears in neutral or with the clutch released. Engage the gears either in low or intermediate speed and use the throttle to govern the speed of the motor. In low gear for every revolution made by the rear wheels, the motor must turn eighty-five times, which acts as an effective brake.
7. If the motor develops a knock it is important the cause be investigated at once and corrected. If not corrected, it becomes more pronounced, thereby causing lack of power and tends to shorten the life of the motor. Never attempt to continue the work with the Tractor when the motor fires only in two or three cylinders. Besides losing power and wasting fuel, it causes raw kerosene to get into the crank case, thinning the lubricating oil.

## The Tractor and Its Operation

*What must be done before starting the Tractor?*

**Answer No. 1**

Before starting the Tractor, the instructions given below must be followed: (1) Fill the radiator with clean water. (See Answer No. 2.) (2) Fill the crank case to the proper level with Tractor lubricating oil of Ford specifications given on page 55. (See Answer No. 3.) (3) Fill the transmission housing to the proper level with Tractor lubricating oil of Ford specifications given on page 55. (See Answer No. 4.) (4) Fill the kerosene tank nearly full. (See Answer No. 5.) (5) Fill the gasoline tank nearly full. (See Answer No. 5.) (6) Fill the air washer with clean water. (See Answer No. 6.)

*What about the Radiator?*

**Answer No. 2**

Before starting the motor, fill the radiator (by removing cover at top; see Plate No. 13) with clean fresh water. If clean water cannot be obtained it is advisable to strain it through muslin or other similar material to prevent any foreign substance from getting in and obstructing the small tubes of the radiator. The system will hold approximately 11 gallons. It is important that the Tractor should not be run under its own power unless the water circulating system has been filled. Pour in the water until you are sure that both radiator and cylinder water jackets are full. The water will run out of the overflow pipe to the ground when the entire system has been properly filled. During the first few days that a new Tractor is being driven, it is a good plan to examine the radiator frequently and see that it is kept filled. Soft rain water, when it is to be had in the clean state, is superior to hard water which may contain alkalies and other salts which tend to deposit sediment and clog the radiator.

*What about the Motor Oiling System?*

**Answer No. 3**

Upon receipt of the Tractor see that a supply of Tractor lubricating oil of Ford specifications given on page 55 is poured into the crank case through the strainer in the breather pipe or oil filler at the left-hand side of the motor. (A metal cap covers it.) At the side of the crank case you will find two small pet cocks. Pour oil in slowly until it runs out of the upper cock. This will take about  $2\frac{1}{4}$  gallons of oil. Leave the cock open until the oil stops running, then close it. Pre-heating the oil in cold weather facilitates pouring. When the Tractor is being worked continuously, oil should be added to the motor twice a day. Under no circumstances should it be allowed to get below the lower cock. Always test oil level when the Tractor is sitting level, motor not running and preferably when it is warm.

*How about the Transmission Oiling System?*

**Answer No. 4**

Before starting the Tractor see that a supply of Tractor lubricating oil of Ford specifications given on page 55 is poured into the transmission housing through the filler hole in the gear shifter cover. With the Tractor sitting level pour the oil in slowly until it reaches the level of the hole. Plenty of time must be allowed for the oil to reach all parts of the transmission and rear axle. Do not replace the filler cap until you are sure the housing has been properly filled. This system holds about three gallons of oil.

*What about Fuel?*

**Answer No. 5**

As the Tractor uses both gasoline and kerosene both tanks should be filled nearly full. The twenty-one gallon kerosene tank is located above the motor and the one-half gallon gasoline tank is bolted to the air washer on the right-hand side of the tank. Strain the fuel to prevent water and other foreign substances getting into the tank. Dirt or water in the fuel is sure to cause trouble. When filling the tanks be sure that there are no naked flames within several feet, as the gasoline vapor is extremely combustible and travels rapidly. Always be careful about lighting matches near where gasoline has been spilled. The small vent hole in the filler cap should not be allowed to get plugged up, as this would prevent the proper flow of the fuel to the vaporizer. The tanks may be drained by removing the pipe plugs at the bottom.

*What about the Air Washer?*

**Answer No. 6**

Before starting the motor fill the air washer with clean fresh water (by removing the filler cap at the side). Pour in the water until it runs out of the filler hole and replace the cap. As the motor draws its air supply through the air washer, a certain amount of water is carried off by the air in the form of moisture. It is necessary to make good this loss by frequently adding more water. If the level is allowed to get too low, the air supply will be shut off thereby causing loss of power or the motor to stop. The air washer should be cleaned out every day by removing the drain plug at the side and flushing out with water.

*How are the Spark and Throttle Levers Used?*

**Answer No. 7**

Under the steering wheel is located the throttle lever which controls the amount of mixture (fuel and air) which goes into the motor. When the motor is in operation the farther this lever is moved backward toward the driver (referred to as opening the throttle) the faster the motor runs or the greater power the power furnished. Mounted on the dash is the spark lever. This lever controls the spark which explodes the gas in the cylinders of the motor. Moving the lever "upwards" advances the spark. It should be moved not beyond this point, a dull knock will be noticed in the motor. (See Chapter on Ignition.)

*Where should these Levers be when the Motor is ready to crank?*

**Answer No. 8**

The spark lever should usually be moved upwards to the third or fourth notch. The throttle should usually be opened about one-third of the way. A little experience will soon teach you where the levers should be placed for proper starting. Care should be taken not to advance the spark lever too far, as the motor may back-fire.

*Where are the Levers on the Vaporizer placed?*

**Answer No. 9**

The vaporizer is attached to the right side of the tractor, fastened on the side of which near the top is located the shifter valve. Turn this lever to the horizontal position, uncovering the letter G, allowing the motor to start on gasoline. Near the center of the vaporizer is a shunt valve lever which controls the amount of heat supplied to the kerosene vapor tube. When starting the motor, move this lever upwards to the "OFF" position so that the exhaust gases will not come directly in contact with the vapor tube. After running the motor until the vaporizer is properly heated (usually one to five minutes, varying with the weather), move the shifter valve lever to the vertical position, uncovering the letter "K" turning the motor on to kerosene. (See Answer No. 59 and Plate 16.)

*What else is necessary before starting the Motor?*

**Answer No. 10**

(1) See that the gear shifter lever on the side of the transmission is in the neutral (central) position, i. e., the position in which it can be moved freely from side to side. (See Plate No. 4.)  
(2) Turn on the stop cock located on right side of vaporizer.  
(3) The next step is to crank the motor.

*How is the Motor Cranked?*

**Answer No. 11**

By lifting the starting crank at the front of the Tractor. Take hold of the handle and push firmly towards the motor until you feel the pin engage the crank ratchet, then lift upwards with a quick swing. With a little experience this operation will soon become an easy matter. Don't, as a usual thing, crank downward against the compression—for then an early explosion may drive the handle vigorously backward. This does not mean, however, that it is not advisable, when the Tractor is hard to start, to occasionally "spin" the motor by the use of the starting handle—but be sure the spark lever is retarded (down) when spinning or cranking the motor against compression, otherwise a sudden backfire may injure the arm of the operator. When cranking the motor the

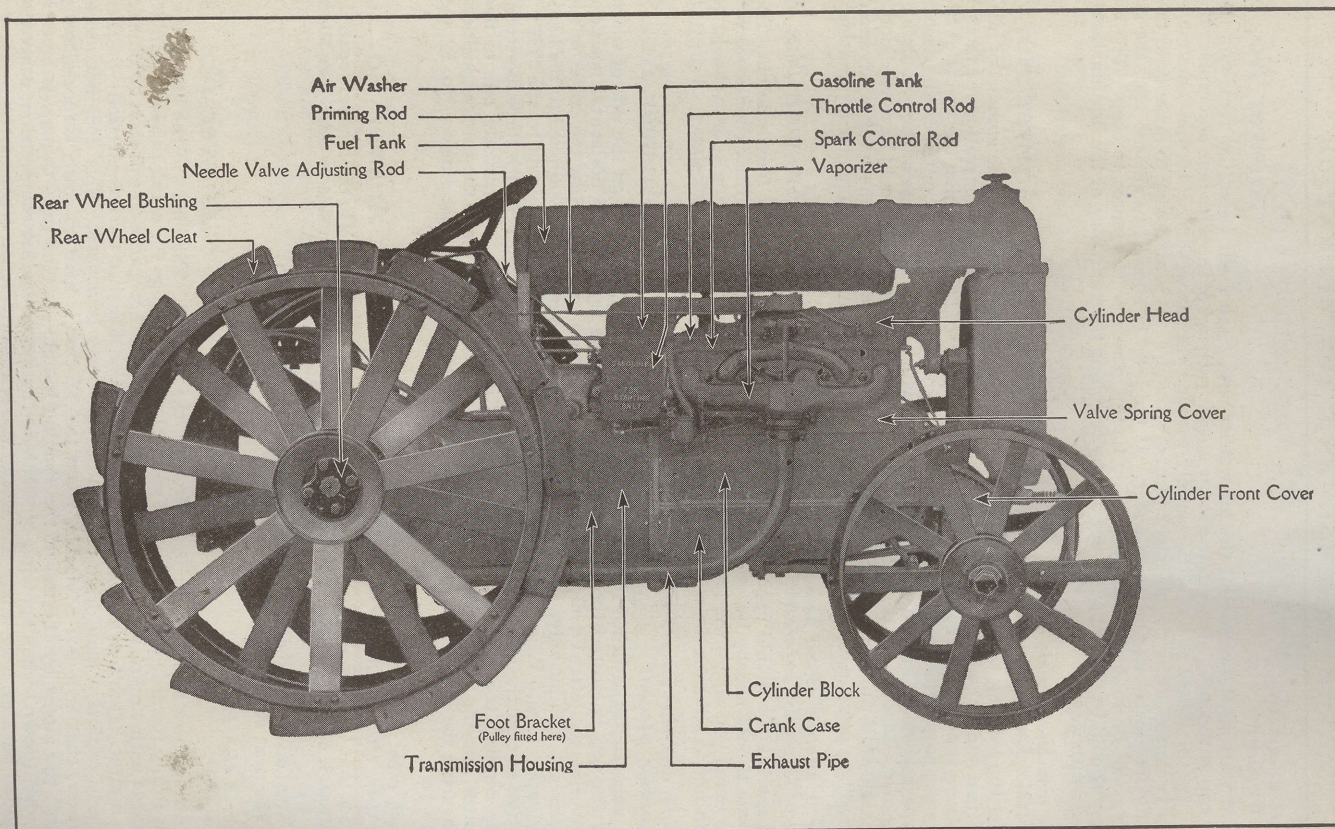

The Fordson Tractor—Vaporizer Side—Plate No. 1

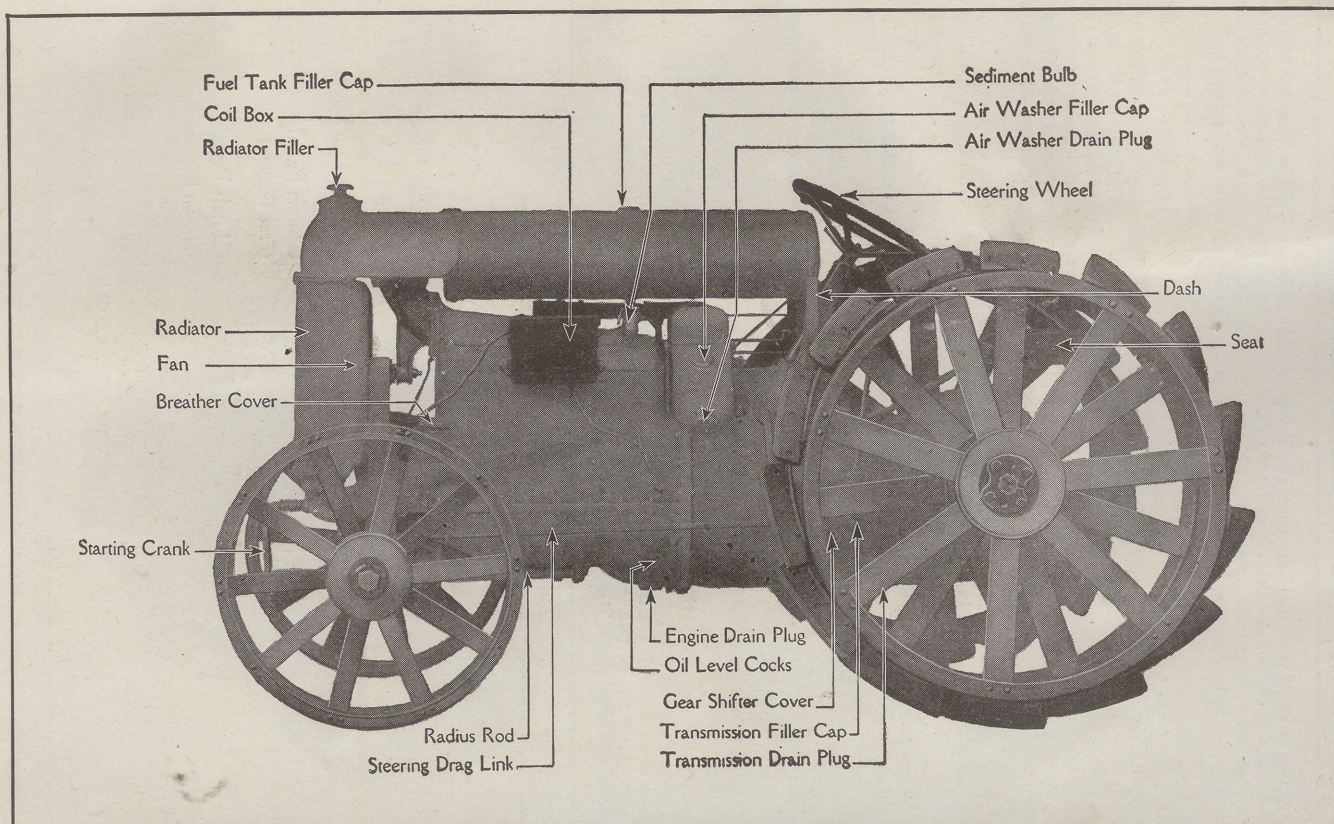

The Fordson Tractor—Coil Box Side—Plate No. 2

priming valve on top of the vaporizer should be almost closed. This is done by pulling out the priming rod on the right-hand side of the dash. As soon as the motor commences to fire regularly the priming rod should be pushed back all the way. Do not keep the priming valve closed too long as the motor may get flooded with gasoline and refuse to fire.

**How is the Motor best started in cold weather?**

As gasoline does not vaporize readily in cold weather it is naturally more difficult to start the motor under such conditions. The usual method of starting the motor when cold is as follows: (1) Close the priming valve by pulling the priming rod on the dash; do not keep the priming valve closed too long as the change that is drawn in is very rich in gas and will not explode readily in the cylinders; (2) give the crank several quick turns; (3) open the priming valve slightly; (4) give the crank one or two turns and the motor should start.

After starting it is advisable to advance the spark two-thirds of the way and let the motor run until it is heated up. If the Tractor is started out with a cold motor it will not have much power and is liable to "stall."

**How does the Clutch Pedal Operate?**

The pedal on the right-hand side of the Tractor operates the clutch. It is used when starting and stopping the Tractor and when changing gears. When pressed downwards it releases the clutch, thus disconnecting the motor from the driving gears. Always allow the clutch pedal to return slowly and smoothly. Sudden engagement of the clutch imposes excessive strain upon all parts and may "stall" the motor.

**Answer No. 13**

**How does the Gear Shifter Lever Operate?**

It is on the left-hand side of the Tractor and engages the gears in the transmission. The lever may be moved to five different positions. When in the neutral (central) position no gears are engaged; the lever must be in this position when the motor is started.

The four positions of the lever which are reached from the neutral position are: Low, Intermediate (Flowing), High and Reverse. (See Plate No. 4.)

**Answer No. 14**

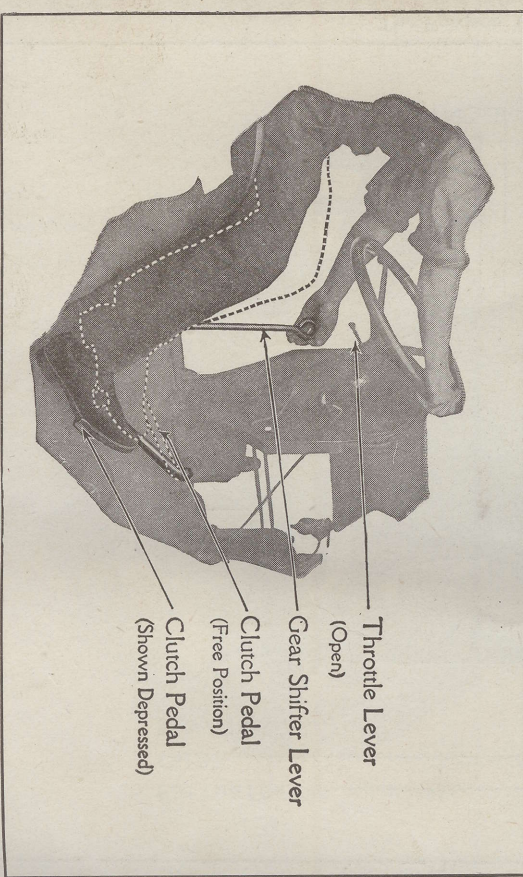

How to Shift Gears—Plate No. 3

**How are the various Gear changes made?**

By moving the gear shift lever, from the neutral position, into the desired positions as given below. (See Plate No. 4.)

**Low:** Move the lever outward to the left from the neutral position, and push forward. **Intermediate (Flowing):** Move the lever outward to the left from the neutral position and pull backward. **High:** Move the lever inward to the right from the neutral position and push forward. **Reverse:** Move the lever inward to the right from the neutral position and pull backward. **ALWAYS RELEASE THE CLUTCH BEFORE ENGAGING OR DIS-ENGAGING GEARS.** Engage the gear in which it is desired to operate the tractor. It is not necessary to start in the low gear. **PRACTICE CHANGING GEARS AND GET ACCUSTOMED TO THEIR VARIOUS POSITIONS BEFORE ATTEMPTING TO START THE MOTOR.**

**Answer No. 15**

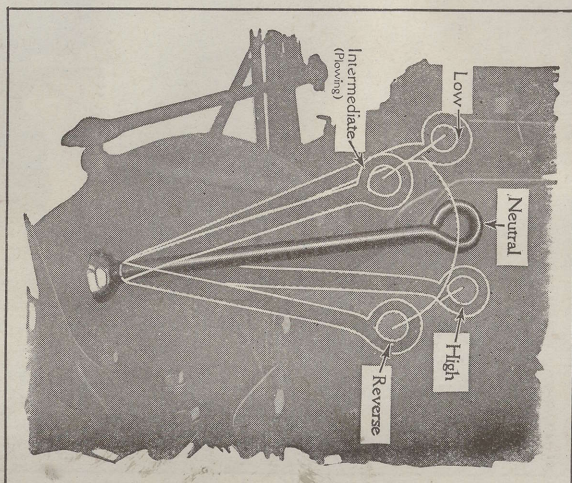

The 5 Positions of Gear Shifter Lever—Plate No. 4

**Answer No. 16**

**How is the Tractor started?**  
After the motor has been started proceed as follows: (1) Push the clutch pedal downward with the foot, which releases the clutch. (2) Move the gear shifter lever into the desired position. (See Answer No. 15.) (3) Then open the throttle slightly and as the speed of the motor increases allow the clutch pedal to return slowly by gradually raising the foot. As the clutch engages, it transmits the driving effort of the motor through the transmission gears to the rear axle, setting the Tractor in motion. If it should happen that the gears are in such a position that the ends of the teeth come against each other instead of sliding past, do not force them, but return the gear shifter lever to the neutral position. Raise the foot, allowing the clutch to engage for an instant; then disengage the clutch by pushing the clutch pedal down and engage the gears as directed above.

**Answer No. 17**

**How is the Tractor stopped?**  
(1) Partially close the throttle. (2) Release the clutch by pushing the clutch pedal downward. (3) Move the gear shifter lever into neutral position—disengaging the gears. (4) Allow the clutch to re-engage by releasing the clutch pedal. **To stop the motor** shut off supply at the sediment bulb and the engine will soon stop for lack of fuel. In cold weather it may be advisable to proceed as follows: Turn shifter to the horizontal position uncovering the letter "G," and pull priming rod out as far as it will go. This has the effect of shutting off the air and filling the cylinders with a rich gasoline vapor which facilitates starting. **Never pull out priming rod while motor is running on kerosene.**

**How is the Spark controlled?**

Good operators drive with the spark lever advanced just as far as the motor will permit. But if the spark is advanced too far a dull knock will be heard in the motor, due to the

**Answer No. 18**

fact that the explosion occurs before the piston in the cylinder has completed its stroke. The spark should only be retarded when the motor slows down under a heavy load or when idling. Care should be taken not to retard the spark too far, for when the spark is late, instead of getting a powerful explosion, a slow burning of gas with excessive heat will result. The greatest economy in fuel consumption is obtained by driving with the spark advanced sufficient to obtain the maximum power.

**How is the speed of the Tractor controlled?**

**Answer No. 19**

By changing the gears to suit load conditions. Always use the highest gear ratio on which the Tractor will give the necessary pull. A little experience will soon teach the driver the proper gears to engage and the best speed at which to run the motor. Never try to do any heavy work in high gear. The speed of the motor is controlled by opening or closing the throttle to suit conditions, and should be kept nearly constant at all working speeds of the Tractor. When running at 1000 revolutions per minute the motor delivers its greatest driving effort and this is the speed at which it should be run when the Tractor is working.

**What are the Tractor Speeds?**

**Answer No. 20**

When the motor is running at 1000 revolutions per minute the four gear changes give the Tractor the following speeds:

Low:  $1\frac{1}{2}$  miles per hour.

Intermediate (plowing):  $2\frac{3}{4}$  miles per hour.

High:  $6\frac{3}{4}$  miles per hour.

Reverse:  $2\frac{1}{2}$  miles per hour.

Use the gear changes to obtain variations in the Tractor speed—Never run the motor above the proper speed.

The speed can be judged by observing the number of complete turns made by the rear wheels in one minute:

In low gear the rear wheels turn 12 times per minute.

In intermediate gear the rear wheels turn 22 times per minute.

In high gear the rear wheels turn 54 times per minute.

In reverse gear the rear wheels turn 21 times per minute.

**Is it advisable for Tractor Drivers to make their own adjustments?**

**Answer No. 21**

The Tractor being of simple construction and very accessible, most of the adjustments the driver will soon learn to make for himself. In making any extensive repairs or replacements it is best to employ the services of a skilled mechanic who thoroughly understands the Tractor.

**What attention does the Tractor need?**

**Answer No. 22**

Remember that a new machine requires more careful attention during the first few days it is being driven than after the parts have been thoroughly "worked in." The Tractor which is driven carefully when new, usually gives the most satisfactory service in the end. See that the Tractor has plenty of oil and water before starting work. If the Tractor is left in the open over night, see that it is properly covered. The Tractor Cover is supplied for that purpose. Nothing will shorten the life of the Tractor more than being left exposed to the weather.

**INSPECT THE TRACTOR DAILY AND SEE THAT ALL BOLTS AND NUTS ARE TIGHT.** Make a practice of taking care of every repair and adjustment as soon as its necessity is discovered. This attention requires but little time and may avoid delay or accident in the field. When the Tractor is delivered it is in proper mechanical adjustment. Afterwards it is plainly the duty of the owner to keep it in that condition.

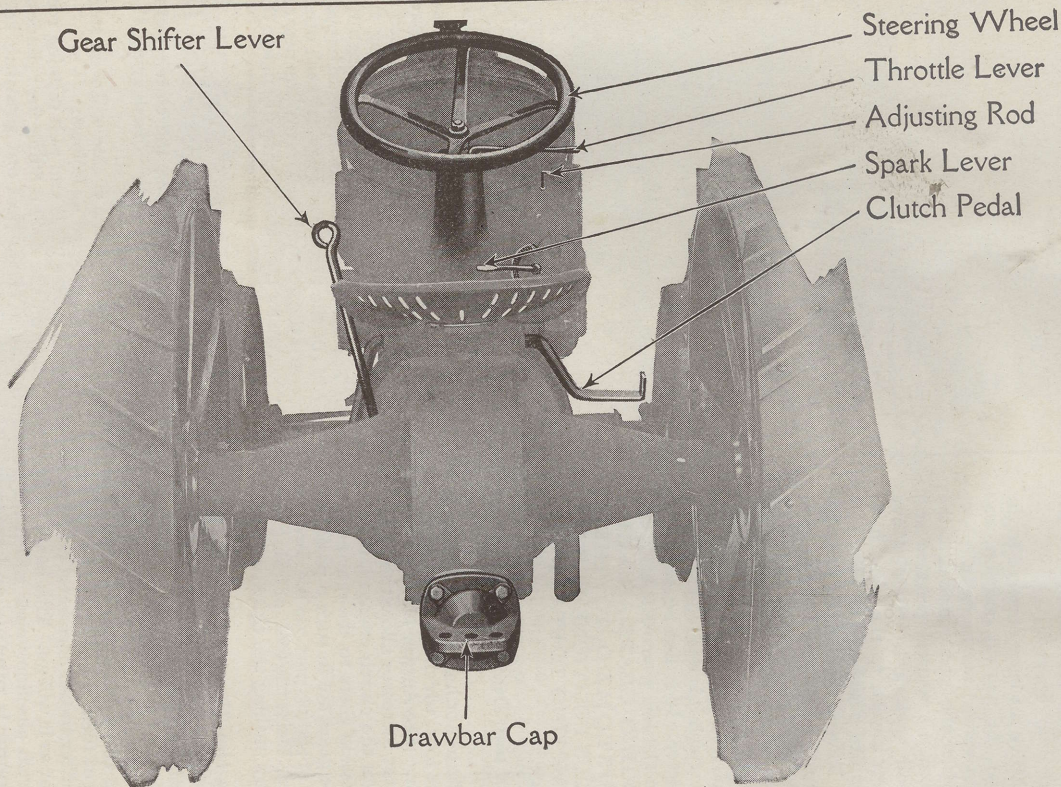

Rear View Showing Controls and Drawbar Cap—Plate No. 5

# The Fordson Motor

## What is the principle of the Tractor Motor?

Gasoline or kerosene vapor when mixed with air and compressed is highly explosive. In the gasoline or kerosene motor such a mixture is drawn into a cylinder, where it is compressed by an advancing piston, and then exploded by an electric spark, which sends the piston downward and through the connecting rod imparts a rotary motion to the crank shaft. (See Plate No. 6.)

**Answer No. 23**

## What are the functions of the Pistons?

On the downward stroke the suction of the piston draws the fresh mixture from the vaporizer, through the intake pipe and valve into the cylinder. The upward movement of the piston compresses the gas into a very small space, between the top of the piston and the depression in the cylinder head, known as the "combustion chamber." (The compressed gases exerting a pressure of approximately 45 pounds per square inch.) At this point the electric spark, generated by the magneto, explodes the gases—driving the piston downward—thus producing the power which turns the crank shaft. On the next stroke upward the piston drives the exploded gas out through the exhaust valve and pipe. These operations are repeated in regular order in each of the four cylinders. Each piston receives an impulse (i. e., force of an explosion) every two revolutions. Plate No. 6 shows clearly the relative positions of the pistons and valves during the different strokes.

**Answer No. 24**

## Why are the Piston Rings necessary?

Three springlike rings are fitted into the grooves around each piston; their purpose is to prevent any part of the gas charge under compression from escaping past the pistons, and thus lessening the force of the explosion. Without these rings it would be impossible to fit the pistons snugly enough in the cylinders to prevent the gas from escaping, without causing undue friction of the piston against the cylinder wall. The expansion of the piston rings reduces this friction to a minimum and still prevents any loss of power through leakage of gas. These rings are sufficiently elastic to allow their being sprung over the pistons in case it should be necessary to replace one. As the friction is practically all on the piston rings, renewing the piston on account of wear is seldom necessary.

**Answer No. 25**

## How are the Connecting Rod and Piston Removed?

Remove the cylinder head (see Answer No. 38), drain oil from motor and remove radius rod and crank case; then disconnect connecting rod from crank shaft and take the piston and rod out through top of cylinder.

**Answer No. 26**

## How are new Piston Rings Fitted?

If the piston rings are worn or scored they should be replaced. In overhauling the motor always remove the piston rings and clean them as well as the grooves. When fitting a new ring, try it around the piston by placing its outside edge in the groove to which it is eventually to be fitted, making certain it is a good fit but not tight in any position. Now place the rim in the cylinder in which it will eventually work. If it is too large in circumference to enter the cylinder, take a small fine-cut file and while holding the ring in a vise file the slot just a little and again try the ring in the cylinder. The top ring should have .005" gap between the ends. The second ring should be fitted with a gap of from .005" to .008", while the lower ring may have an even larger gap. Care must be taken when fitting the ring to make sure it is inserted absolutely true; otherwise, bad fitting will result and a consequent "sluggish" running of the motor. On one side of the ring is a punch mark. This side must be placed towards the top of the piston in replacing. If the piston pin is worn and has appreciable shake in the piston, the entire piston should be replaced.

**Answer No. 27**

## What is the Valve Arrangement?

Two valves—one intake and one exhaust—are located in each cylinder. The former admits the fresh gas drawn from the vaporizer through the intake pipe. The latter per-

**Answer No. 28**

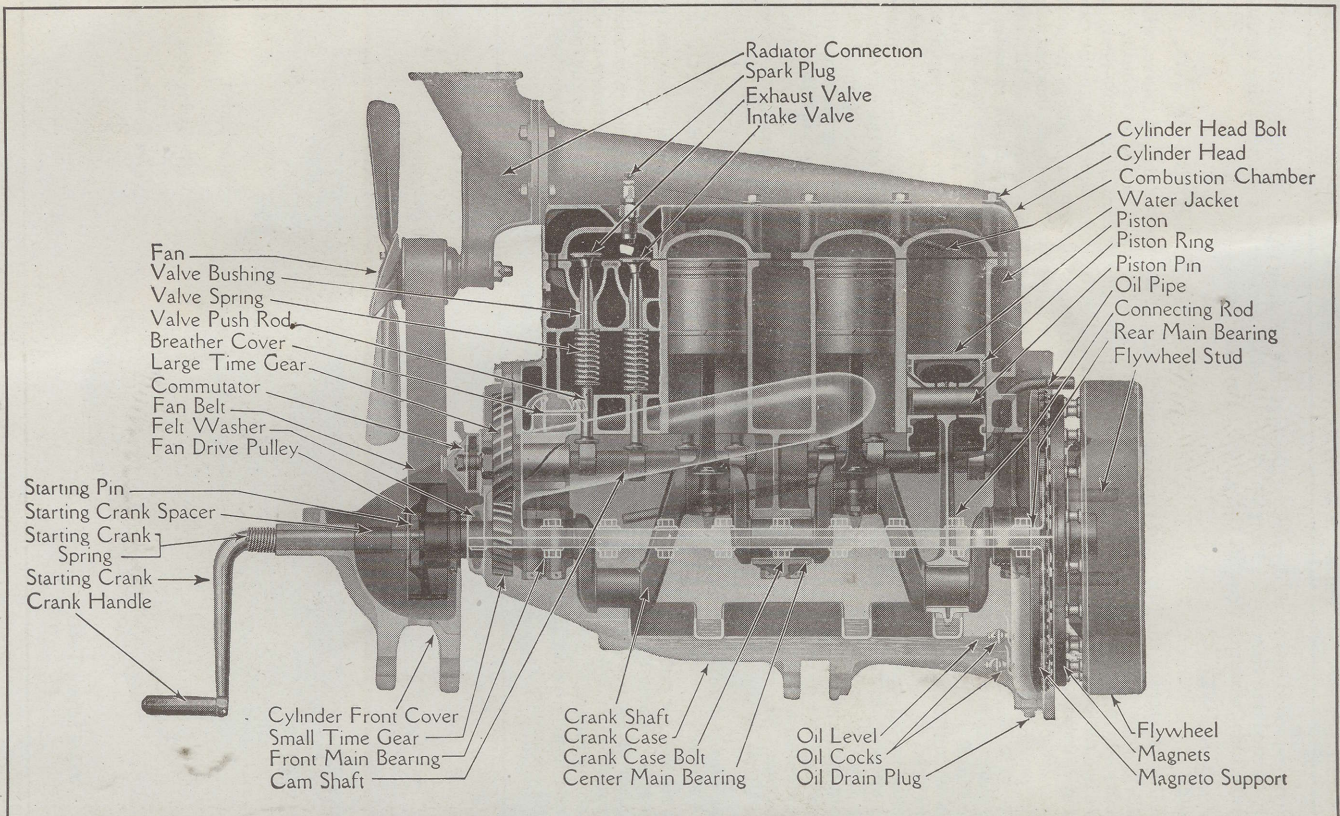

Sectional View of the Fordson Motor—Plate No. 6



mits the exploded gas to be driven out through the exhaust pipe. The valves are alternately opened and closed (see Plate No. 8) by the cams on the cam shaft striking against the push rods, which in turn lift the valves from their seats.

**How are the Valves Timed?**

In timing the motor the points of opening and closing of the valves are, of course, what should be considered. As the valves are properly timed when the motor is built, the necessity for retiming would occur only when such parts as the cam shaft, time gears or valves are removed in overhauling the motor. In fitting the large time gear to the cam shaft it is important to see that the first cam points in the direction opposite to the zero mark. (See Plate No. 8.) The time gears must also mesh so that the tooth marked zero on the small time gear will come between the two teeth on the large gear at the zero point. The time gears now being properly set, the exhaust valve on No. 1 cylinder is open and the intake valve closed, the other valves being in the position indicated in Plate No. 8. The opening and closing of the valve being as follows: The exhaust valve opens when the piston reaches  $\frac{1}{4}$  inch of bottom center, the distance from the top of the piston head to the top of the cylinder casting measuring  $4\frac{11}{16}$  inches. The exhaust valve will close on top center, the piston then being  $\frac{1}{16}$  inch above cylinder casting. The intake valve opens  $\frac{3}{4}$  inch to  $\frac{1}{16}$  inch after top center, the distance from top of the piston then being from  $\frac{3}{4}$  inch to level with cylinder casting, and closes  $\frac{1}{16}$  inch to  $\frac{1}{16}$  inch after bottom center, the distance from the top of the pistons to the top of the cylinder casting measuring from  $4\frac{11}{16}$  inches to  $4\frac{1}{2}$  inches. The clearance between the push rod and the valve stem should be .020 inch and should be measured when the push rod is on the heel of the cam. When retiming, the opening of the intake valve and the closing of the exhaust valve are the points which should be observed.

**Answer No. 29**

**What about the care of the Valves?**

They seldom get out of order, but they do get dirty as a result of carbon collecting on the valve seat. These carbon deposits, by preventing proper closing of the valves, permit the gases under compression to escape, resulting in loss of power and uneven running of the motor. If, when turning the motor over slowly, there is lack of resistance in one or more cylinders, it is probable that the valves need regrounding. As the life of the motor depends largely upon the proper seating of the valves, it is necessary that they be ground occasionally.

**Answer No. 30**

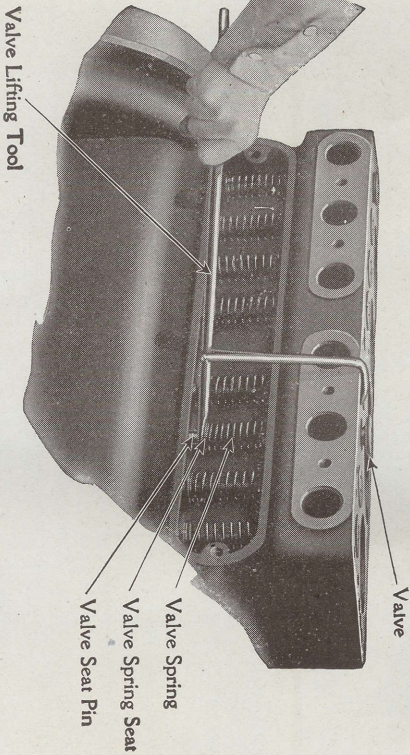

How to Use a Valve Lifting Tool—Plate No. 7

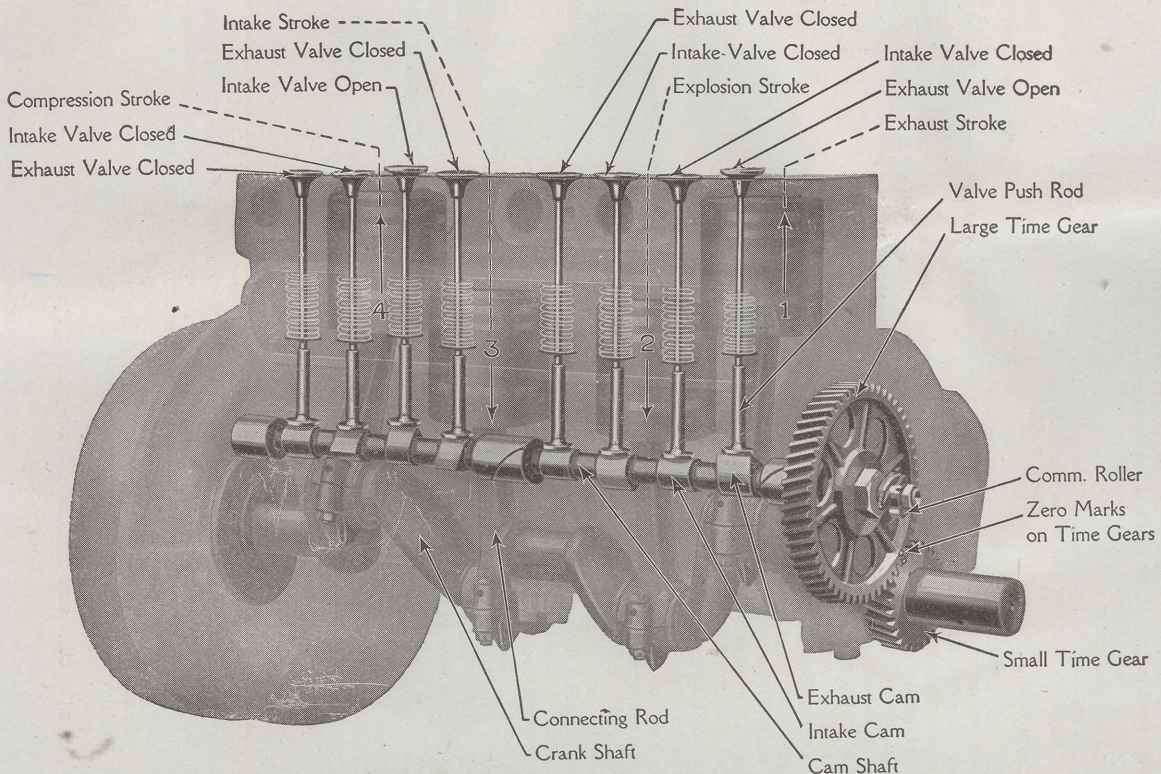

Cylinder Assembly, showing correct position of the valves with time gears properly set according to punch marks on the gears, also the relative position of pistons in their strokes as indicated above. The firing order of the cylinders is 1, 2, 4, 3—Plate No. 8

### How are Valves removed for grinding?

(1) Drain radiator; (2) remove cylinder head (see Answer No. 38); (3) remove valve spring cover from the side of the cylinder; (4) raise valve spring with lifting tool and pull out the little pin under the valve spring seat. (See Plate No. 7.) The valve may then be lifted out by the head preparatory to grinding. Remove and grind only one valve at a time so that no mistake can be made in replacing.

### How are the Valves ground?

For this work use a good prepared grinding compound, or a paste made of ground glass and oil. A convenient way is to put a small amount into a suitable dish adding a spoonful or two of kerosene, and a few drops of lubricating oil to make a thin paste. Place the mixture sparingly on the bevel face of valve. Put the valve in position on the valve seat and rotate it back and forth (about a quarter of a turn) a few times with a grinding tool. (See Plate No. 9.) Then lift slightly upon the seat, change the position and continue the rotation, and keep on repeating this operation until the bearing surfaces are smooth and bright. The valve should not be turned through a complete rotation, as this is apt to cause scratches running around the entire circumference of the valve and seat. When the grinding is completed the valve should be removed from the cylinder, thoroughly washed with kerosene and the valve seat wiped out thoroughly. Extreme care should be taken that no abrasive substance gets into the cylinders or valve guides. This can be avoided if the grinding paste is applied sparingly to the bevel face of the valve. If the valve seat is worn badly or seamed it is best to have it reseated with a valve seating tool. The operation requires considerable skill, and perhaps had better be done by an expert mechanic. Care should be exercised against making too deep a cut necessitating the retriming of the valves.

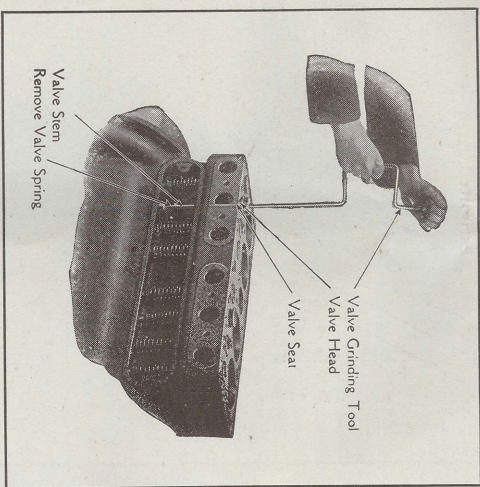

Method of Grinding Valve—Plate No. 9

When the valves or push rods become worn so as to leave too much play between them thus reducing the lift of the valves and diminishing the power of the motor, it is best to replace the push rods with new ones. The clearance between the push rods and the valve stem should be .020 inch and must never be greater than  $\frac{3}{32}$  inch nor less than  $\frac{1}{16}$  inch. If the clearance is greater the valve will open late and close early, resulting in uneven running of motor. If the clearance is less than  $\frac{1}{16}$  inch the valve stem may be filed off. If more than  $\frac{3}{32}$  inch replace the valve or push rod. We do not recommend drawing out the valve stems, as the operation requires experience, and the price of the new part does not warrant the time and expense necessary to do the work properly.

### When the Valves and Push Rods are worn—What?

When the valves or push rods become worn so as to leave too much play between them thus reducing the lift of the valves and diminishing the power of the motor, it is best to replace the push rods with new ones. The clearance between the push rods and the valve stem should be .020 inch and must never be greater than  $\frac{3}{32}$  inch nor less than  $\frac{1}{16}$  inch. If the clearance is greater the valve will open late and close early, resulting in uneven running of motor. If the clearance is less than  $\frac{1}{16}$  inch the valve stem may be filed off. If more than  $\frac{3}{32}$  inch replace the valve or push rod. We do not recommend drawing out the valve stems, as the operation requires experience, and the price of the new part does not warrant the time and expense necessary to do the work properly.

### What about the Valve Springs?

When the valves fail to seat themselves properly, there is a possibility that the springs may be weak or broken. A weak inlet spring would probably not affect the running of the motor, but weakness in the exhaust valve spring causes a very uneven action which is difficult to locate. The symptoms are a lag in the motor due to the exhaust valve not

### Answer No. 31

### Answer No. 32

closing instantaneously, and as a result, a certain percentage of the charge under compression escapes, greatly diminishing the force of the explosion. Weakness in a valve spring can usually be detected by the following method: Remove the plate which encloses them at the side of the cylinder and insert a screw-driver between the coils of the spring while the motor is running. If the extra tension thus produced causes the motor to pick up speed, the spring is obviously weak and should be replaced with a new one.

### What causes "Knocking" in the Motor?

There are several causes which may be enumerated as follows: (1) Carbon knock, which is by far the most common, resulting from carbonizing of cylinders; (2) knock caused by too advanced a spark; (3) connecting rod knock; (4) crank shaft main bearing knock; (5) knock due to loose-fitting piston or broken ring; (6) knock caused by piston striking the cylinder head gasket. When the motor knocks from any cause whatsoever, the matter should be properly investigated by an experienced mechanic and the difficulty remedied.

### How may the different Knocks be distinguished?

(1) The carbon knock is a clear, hollow sound most noticeable when pulling hard, particularly when the motor is heated. It is also indicated by a sharp rap immediately on advancing the throttle. (2) Too advanced spark will be indicated by a dull knock in the motor. (3) The connecting rod knock sounds like the distant tapping of steel with a small hammer, and is readily distinguished when the motor is allowed to run free. (4) The crank-shaft main bearing knock may be distinguished when the Tractor is pulling hard as a dull thud. (5) The loose piston knock is heard upon suddenly opening the throttle when the sound produced might be likened to a rattle. The remedies for these knocks are treated under their proper divisions.

### How is Carbon removed from Combustion Chamber?

Remove the cylinder head (see Answer No. 38). Then with a putty knife or screw-driver scrape from the cylinder and piston heads the carbonized matter, being careful to prevent the specks of carbon from getting into the cylinders or bolt holes or under the valves. Before replacing the cylinder head wipe off each valve and valve seat with a clean cloth. In replacing cylinder head be careful that it is tightened down properly.

### How is the Cylinder Head removed?

(1) Open the small cock under the radiator and drain off all water. (2) Shut the stop cock on the sediment bulb and remove the fuel tank. (3) Disconnect all wires from motor and remove coil box; do not disconnect commutator but remove it along with the wires. (4) Remove the four bolts holding the cylinder head to radiator connection. (5) Remove the 22 cap screws which hold the cylinder head in place. (6) Take off the cylinder head, taking care not to damage the gasket. In replacing the cylinder head clean the surfaces on the cylinder head and turn the motor over so that No. 1 and No. 4 pistons are at top center; place the gasket in position over the pistons and then put the cylinder head in place. Be sure and draw the cylinder head cap screws down evenly (i. e., give each a few turns at a time).

### How are the Sparks Plugs cleaned?

After removing the plugs from the motor, the points may be cleaned with an old tooth-brush dipped in gasoline. However, in order to do the work thoroughly, the plugs should be taken apart by securing the large hexagon steel shell in a vise and loosening the pack nut which holds the porcelain in place. The carbon deposit can then be easily removed from the porcelain and shell by a small knife. Care should be exercised not to scrape off the glazed surface of the porcelain, otherwise it will be apt to carbonize quickly. In assembling the plug care should be taken to see that the pack nut is not tightened too much so as to crack the porcelain. The distance between the sparking points should not be more than  $\frac{3}{32}$  of an inch, about the thickness of a smooth dime. Dirty plugs are usually a result of using too rich a gas mixture, or from an excess of oil being carried in the crank case.

### Answer No. 33

### Answer No. 34

### Answer No. 36

### Answer No. 37

### Answer No. 38

### Answer No. 39

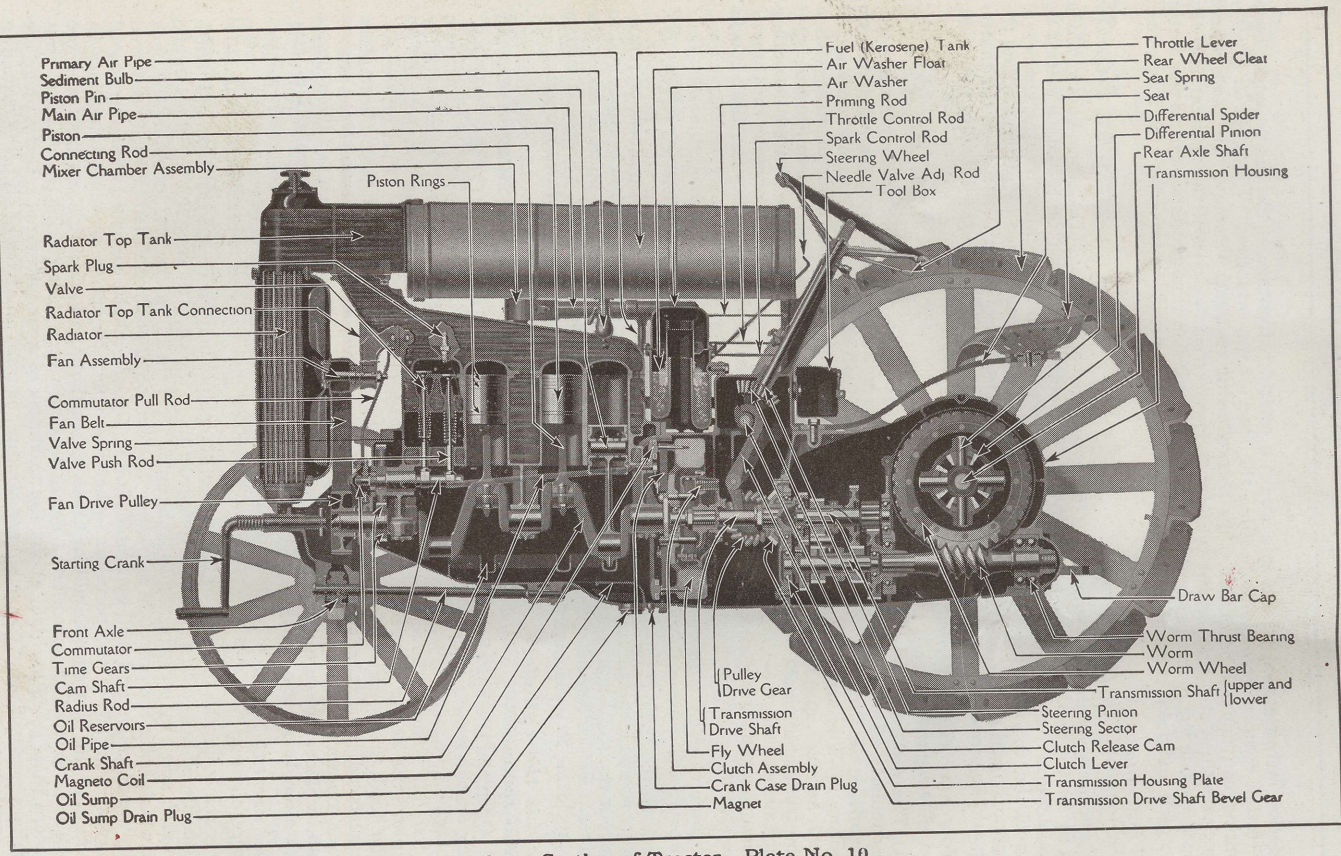

Cross Section of Tractor—Plate No. 10

**Connecting Rod Bearings—**

**How adjusted?**

Connecting rod bearings may be adjusted without taking the motor apart by the following method: (1) Drain off the oil from the motor. (2) Remove the radius rod and crank case—exposing connecting rods. (3) Take off the first connecting rod cap and remove a shim from each side. (4) In replacing cap be sure to place it in the same position as when removed so that the punch marks will correspond, then tighten bolts until it fits shaft snugly. (5) Test tightness of bearing by turning motor over with the starting crank. It may be necessary to remove the cap several times and remove or add shims as required. Experienced mechanics usually determine when bearing is properly fitted by lightly tapping each side of the cap with a hammer. (6) Then loosen the bearing and proceed to fit the other bearings in the same manner. (7) After each bearing has been properly fitted and tested, tighten the cap bolts and the work is finished. Remember there is a possibility of getting the bearings too tight, and under such conditions the babbit is apt to come out quickly unless precaution is taken to run the motor slowly at the start. It is a good plan after adjusting the bearings to run the motor for some little time (keeping it well supplied with water and oil) before working it. Whenever possible these bearings should be fitted by an expert mechanic.

**Crank Shaft Main Bearing—**

**How adjusted?**

Should the stationary bearings in which the crank shaft revolves become worn (see Answer No. 36) they may be adjusted without taking the motor apart as follows: (1) Drain the oil from the motor. (2) Remove the radius rod and the crank case—exposing the crank shaft and main bearings. (3) Remove the rear main bearing cap. (4) Between the two halves of the bearing will be found a number of shims .003 in. and .006 in. thick. Remove shims of equal thickness from each side of the cap; then place the cap in position and tighten up as much as possible without stripping the bolt threads. (5) Test the tightness of the bearing by turning the motor over with the starting crank. If the crank shaft cannot be turned with one hand, the contact between the bearing surfaces is evidently too close and will require shimming up. In case the crank shaft moves too easily more shims should be removed; the correct adjustment being obtained by removing or adding thin or thick shims as determined by trial. (6) Then loosen the bearing and proceed to fit the center bearing in the same manner. Repeat the operation with the front bearing, with the other two bearings loosened. (7) Should any end play be noticed in the crank shaft use a No. 3 crank shaft bearing cap (part No. S-230) on No. 3 main bearing. (8) When the proper adjustment of each bearing has been obtained place a little lubricating oil on the bearings, also on the crank shaft; then draw the caps up as closely as possible—the necessary shims, of course, being in place. Do not be afraid of getting the cap bolts too tight, as the shims under the cap and the oil between the bearing surfaces will prevent the metal being drawn into too close contact. If oil is not put on the bearing surfaces, the babbit is apt to cut when the motor is started up before the oil in the crank case can get into the bearing. Be careful to lock all bearing cap bolts with wire before replacing crank case.

**How is the Motor removed from the Transmission?**

When it is necessary to disassemble the motor or transmission for repairs or adjustment proceed as follows: (1) Drain the oil from the radiator. (2) Empty radiator and water jackets by opening the small cock under the radiator. (3) Close stop cocks on sediment bulb and gasoline tank and remove fuel tank. (4) Remove the air washer and gasoline tank. (5) Disconnect the steering arm from the drag link and the control rods from the commutator and vaporizer. (6) Remove the dash by unscrewing the four cap screws holding it to the transmission housing. (7) Block up the transmission housing as well as the motor separately, being careful to place a wedge on both sides between the cylinder front cover and the front axle so as to prevent the motor from tilting over when it is disconnected. (8) Remove the bolts from the cylinder flange holding the motor to the transmission housing; the rear part of the Tractor can then be drawn away from the motor. (See Plate No. 11.) When assembling the Tractor, it is important that the two bolts, one on each side of the cylinder flange, just above the crank case, be inserted first. The holes in which these

**Answer No. 40**

**Answer No. 41**

**Answer No. 42**

two bolts fit are smaller and being reamed accurately they bring the motor and transmission into correct alignment.

**What about the Gaskets?**

**Answer No. 43**

In taking the Tractor apart care should be exercised, so that the paper gaskets are not torn. If they are damaged, they should be replaced with new ones. Many of the gaskets used in the Tractor are made of paper, and if desired may be made from ordinary newspaper. Gaskets which can be so replaced are S4, S257, S326, S328, S354 and S791. It is best when fitting a new gasket to varnish one side with shellac. It will then stick to one surface and is not so liable to be torn when the joint is taken apart.

## The Cooling System

**What is the purpose of the Cooling System?**

**Answer No. 44**

The heat generated by the successive explosions in the cylinders would soon overheat and ruin the motor were it not cooled by some artificial means. The Tractor motor is cooled by the circulation of water in jackets around the cylinders. The heat is taken from the water by radiation in its passage through the thin metal tubing of the radiator to which are attached thin brass fins, which assist in the rapid radiation of the heat. The fan, just back of the radiator, assists in the cooling of the water by sucking the air through the fins and around the tubes.

**How does the Water circulate?**

**Answer No. 45**

The cooling apparatus of the Tractor is known as the Thermo-Syphon system. As hot water is lighter than cold, it always seeks the higher level, consequently when the water is heated in the cylinders, it rises to the top tank and is replaced in the cylinders with cooler water from the bottom tank, which, in turn, is supplied through the radiator tubes. This circulation then continues only so long as the water level is above the upper connection. No pump or mechanical device is necessary to keep the circulation constant. (See Plate No. 12.)

**What are the causes of Overheating?**

**Answer No. 46**

The motor may be overheated by (1) carbonized cylinders; (2) spark retarded too far, causing late ignition; (3) poor ignition; (4) not enough or poor grade oil; (5) racing motor; (6) improper vaporizer adjustment; (7) fan not working properly on account of broken or slipping belt; (8) improper circulation of water due to clogging of radiator tubes or low water level.

**What should be done when Radiator overheats?**

**Answer No. 47**

The capacity of the radiator being 11 gallons no trouble from overheating should be experienced if the radiator is kept full. Don't be alarmed if it boils occasionally—especially when working on heavy ground in hot weather. Remember that the motor develops the greatest efficiency when the water is heated nearly to boiling point. But if there is continuous overheating when the motor is working under ordinary conditions, find the cause of the trouble and remedy it. The chances are that the difficulty lies in improper driving or carbonized cylinders. By reference to the proper division of this book each of the causes which contribute to an overheated radiator is treated and remedies suggested. No trouble can result from the filling of a heated radiator with cold water, provided the top tank is not entirely empty, in which case the motor should be allowed to cool before the cold water is introduced.

**How often should Water be put in the Radiator?**

**Answer No. 48**

Several times a day in hot weather. The radiator at all times ought to be kept full or trouble is sure to follow. It is a good plan to make it a habit to fill the radiator always

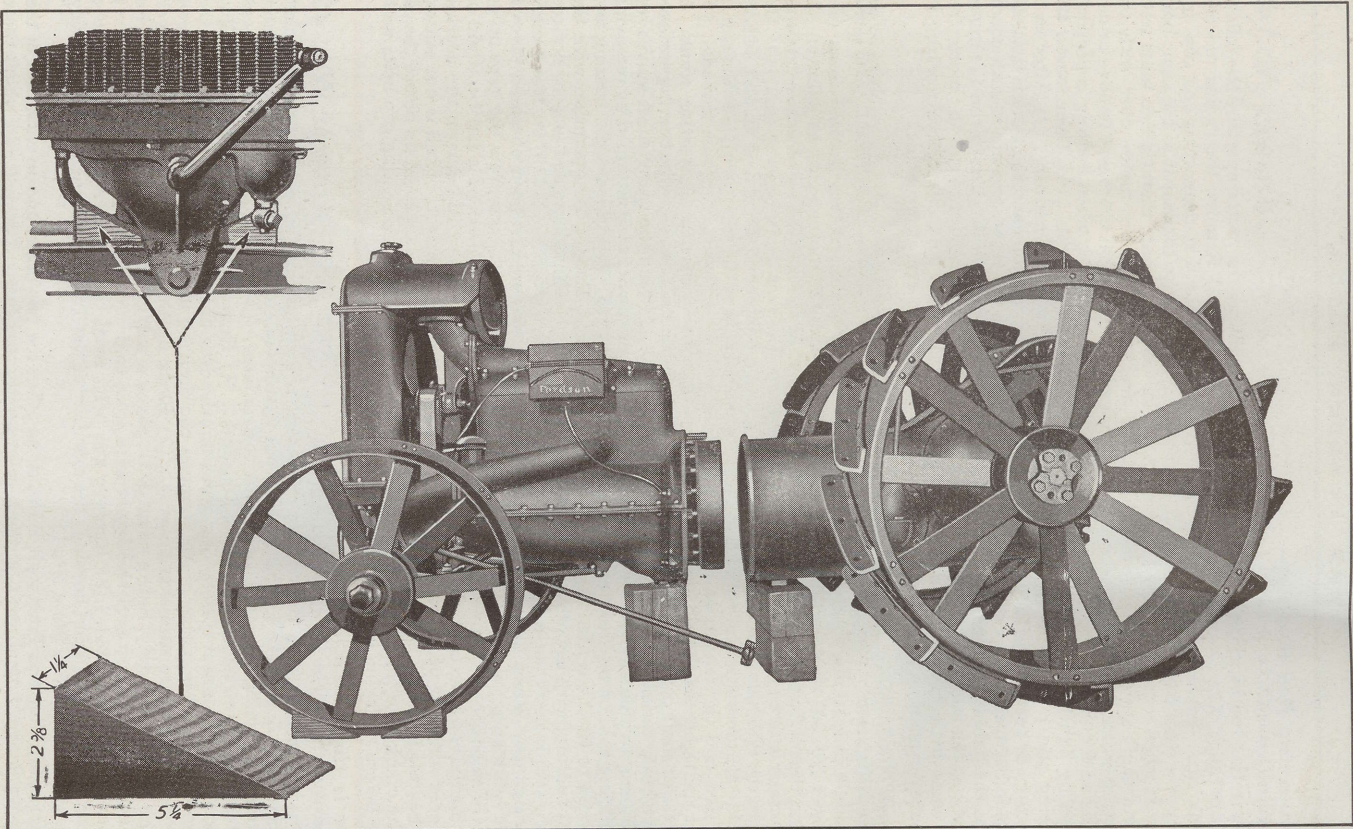

Separating Motor from Transmission—Plate No. 11

before starting the Tractor and whenever a stop is made for oil or fuel. The importance of keeping the radiator filled cannot be impressed too often upon the new driver. To remove the radiator cover for filling, unscrew the nut on top a few turns, then push the cover back over the tank. (See Plate No. 13.)

#### Will the Radiator freeze in Winter?

**Answer No. 49**

As the circulation does not commence until the water becomes heated, it is necessary to use an anti-freezing solution in the circulating system, in winter when the temperature is below the freezing point. In case any of the radiator tubes happen to be plugged or jammed they are bound to freeze and burst open if the driver undertakes to get along without using a non-freezing solution. Wood alcohol or denatured alcohol can be used to good advantage for an anti-freezing solution.

The following table gives the freezing points of solutions containing different percentages of alcohol:

20% solution freezes at 15° above zero
30% solution freezes at 8° below zero
50% solution freezes at 34° below zero

A solution composed of 60% water, 10% glycerine and 30% alcohol is commonly used, its freezing point being about 8 degrees below zero. On account of evaporation fresh alcohol must be added frequently in order to maintain the proper solution. If an anti-freezing solution is not being used in frosty weather, it is essential that the radiator be drained if the Tractor is left out during the night and refilled next morning.

#### How about cleaning the Radiator?

**Answer No. 50**

The entire circulating system should be thoroughly flushed out occasionally. Simply open the drain cock in front of the motor under the radiator and flush out the entire system by pouring water into the top tank from whence it will flow down through the tubes and also through the water jackets in the cylinder and out at the drain cock. Should the tubes become clogged inside and the water will not remove the obstruction they can be cleared by means of a thin strip of soft copper wire or cane inserted through the filler hole. When the fins and tubes become clogged outside with chaff, seeds, dust, etc., they should be cleaned, because otherwise the air circulation is retarded.

#### How are Leaks and Jams in the Radiator repaired?

**Answer No. 51**

A small leak may be temporarily repaired by applying brown soap or white lead, but the repair should be made permanent with solder as soon as possible. A jammed radiator tube is a more serious affair. While the stopping of one tube does not seriously interfere with the circulation, it is bound to cause trouble sooner or later, and the tube will freeze in cold weather. Remove the radiator core and insert a new tube. If the entire radiator is badly choked or broken, it is advisable to install a new core.

#### How is Radiator Removed?

**Answer No. 52**

- (1) Drain off water by opening cock under radiator.
- (2) Remove the three cap screws under bottom tank which holds radiator to cylinder front cover.
- (3) Loosen front fuel tank strap by removing the two nuts (on cover of radiator).
- (4) Unscrew the four cap screws under top tank which holds radiator to top tank connection.
- (5) Then lift off radiator. Be careful not to damage gaskets used to keep the connections water tight.

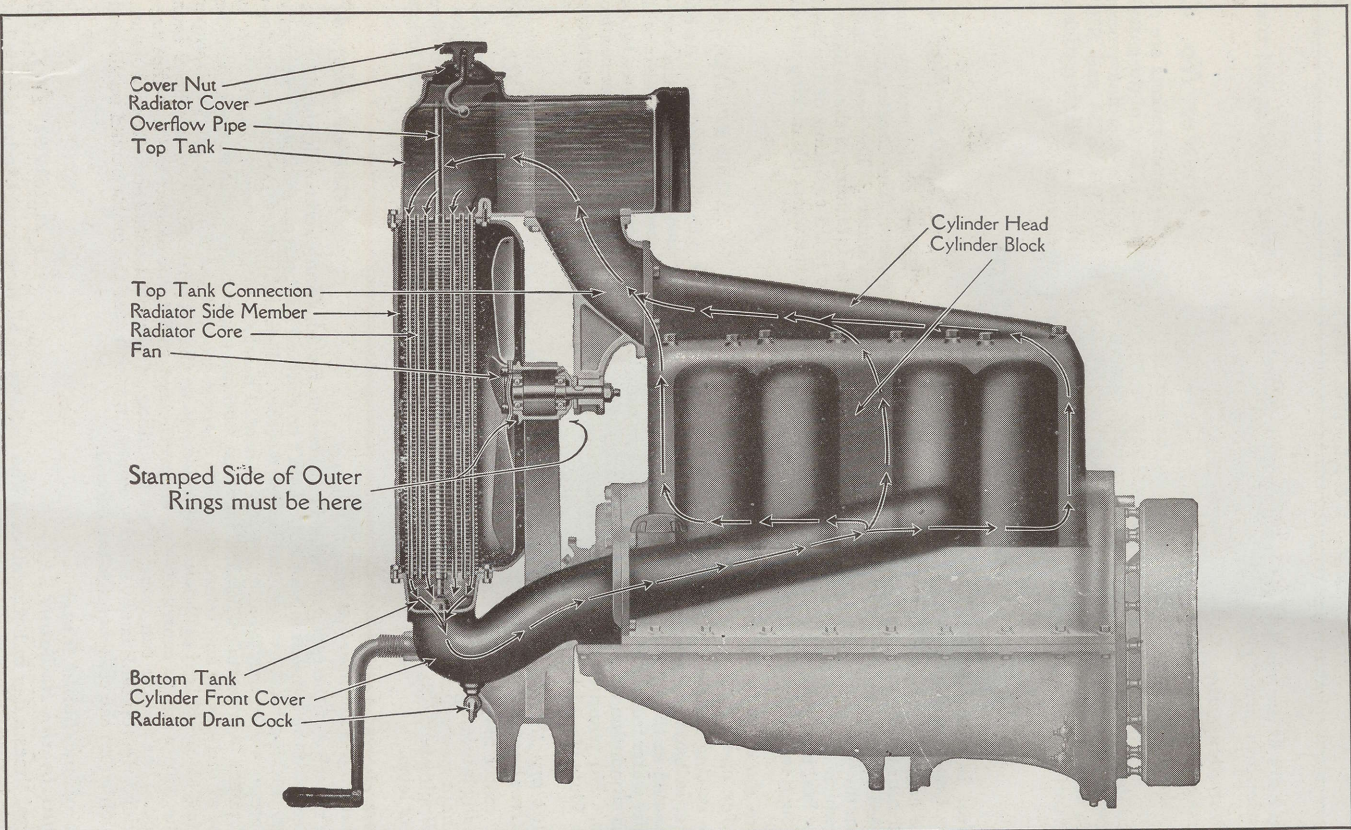

The Thermo-Syphon Cooling System Showing Course of Water—Plate No. 12

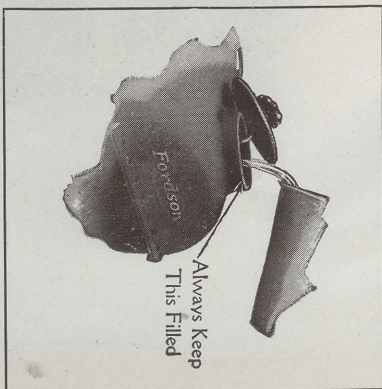

Filling Radiator—Plate No. 13

*What attention does the Fan require?*

**Answer No. 53**

It should be lubricated once a week by unscrewing the oil plug and filling the hub with heavy fluid gear oil. The belt should be inspected frequently and tightened when necessary. To do this, remove the cotter pin holding the nut on rear end of the fan shaft; loosen the nut a little, then place a wrench on the square end of the shaft and turn until the belt is sufficiently tight, hold the wrench in this position and tighten up the nut, afterwards replacing the cotter pin. (See Plate No. 14.) Do not tighten the belt too much as it may cause undue wear on the bearings. The belt is sufficiently tight when it will just slip when the fan is pulled around by hand. Be sure there is always plenty of clearance between the fan blades and fan belt and that the fan shaft nut is kept tight.

## Air Washer

*What is the purpose of the Air Washer?*

**Answer No. 54**

It serves two purposes. First: To remove all dust and solid matter from the air before it enters the cylinders of the motor, preventing excessive wear to the pistons and cylinder walls. Second: It moistens the air in its passage through the water and helps to avoid pre-ignition of the gas mixture in the cylinders.

*How does the Air Washer Operate?*

**Answer No. 55**

The suction of the pistons in the cylinders draws the air into the air washer through the central passage. It is then guided downward and into the water. In its passage through the water it gets rid of all dust and becomes moist. The air is then drawn off through the tube flange on top to the vaporizer. (See Plate No. 15.)

*What is the function of the Float?*

**Answer No. 56**

In order to get proper operation of the air washer, it is necessary that the air should enter the water at a certain distance below the water level. To compensate for the variation in the water level a float is used. The float then keeps the open end of the air guide at the proper distance under water.

*What attention does the Air Washer need?*

**Answer No. 57**

The dust collected from the air deposits in the air washer, causing the water to become muddy and also forming a sediment in the bottom of the bowl. This water and mud should be removed daily. The water is drained by removing the drain plug. (See Plate No. 15.) This should be done immediately upon stopping the Tractor after it has been run, as at this time there is very little sediment, due to the agitation of the water. After the water has been drained out remove the filler cap and flush the tank out with a hose. If no hose is available, replace the drain plug and pour a pailful of water into the bowl. The water may be agitated by starting and running the Tractor for a short distance, repeating the operation until the water drained from it is reasonably clear. If the water level is allowed to become low the guide fixed to the float cuts off the air supply, causing loss of power and the motor to miss fire or stop.

## Fuel System

*What is the purpose of the Vaporizer?*

**Answer No. 58**

It is the device in which the fuel is mixed with the correct proportion of air to form a "charge" which is sucked into the cylinders and then exploded by an electric spark. The vaporizer is so constructed as to allow for varying the proportions of air and fuel to meet conditions.

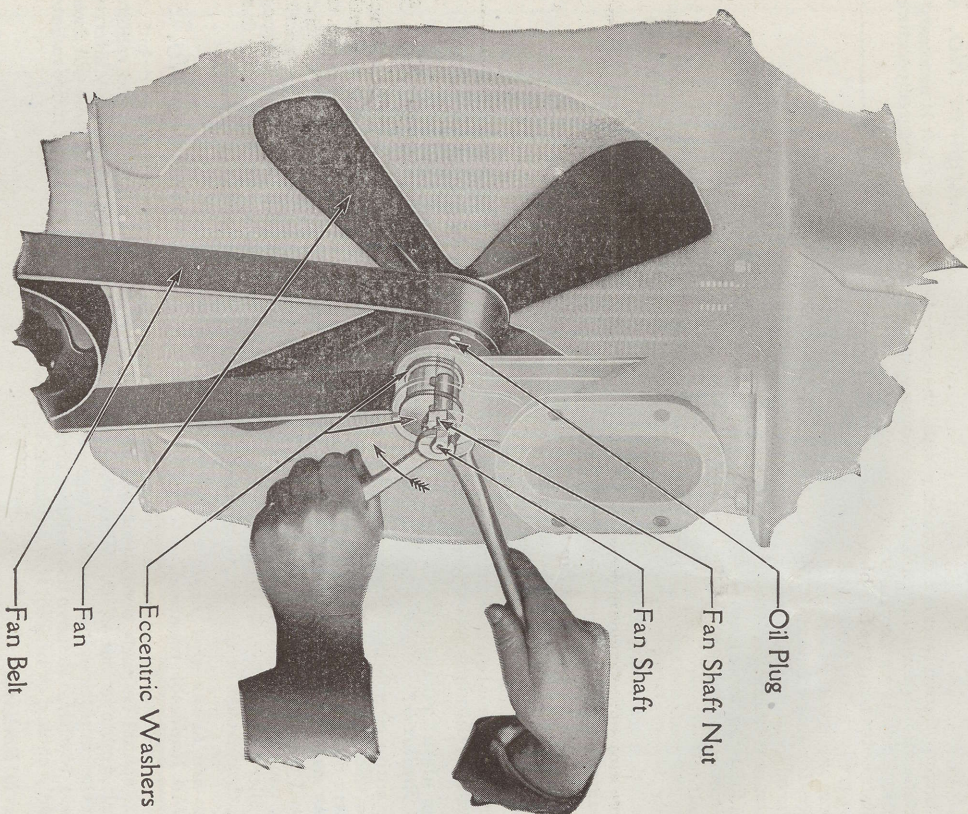

Adjusting Fan Belt—Plate No. 14

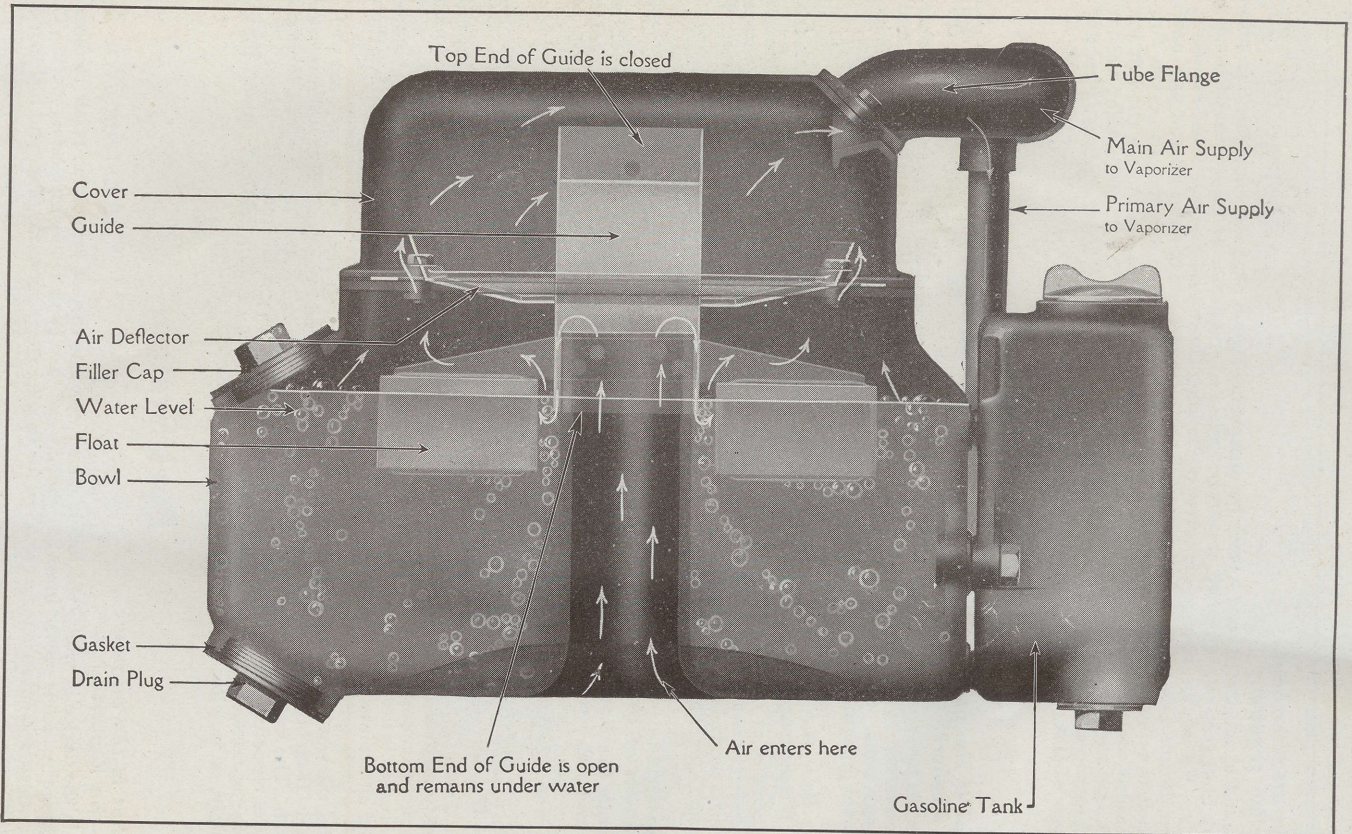

Air Washer Showing Principle and Operation—Plate No. 15

### How does the Vaporizer work?

The Tractor having two fuel systems, i. e., gasoline and kerosene, the vaporizer is designed to work with either. The view of the vaporizer on page 28 shows its operation. When using gasoline for starting with the old type vaporizer, the shifter valve is turned to the horizontal position, uncovering the letter "G" or with the new type vaporizer the two-way valve is turned to "Gas." This shuts off the flow of kerosene and allows gasoline to enter the mixing chamber. In the mixing chamber it is vaporized by the air drawn through the main air tube and past the shifter valve. No heat is used to vaporize the gasoline.

After the motor has been running at least one minute, the shifter valve is turned to the vertical position, uncovering the letter "K" or the two-way valve is turned to "Ker." (See Plate No. 16.) The paths of the air, fuel, mixtures and exhaust gases are indicated by arrows as explained by the key on the diagram, Plate 17. It will be noted that there are two separate keys on Plate 18, which shows phantom sectional views of the float and mixing chambers. The kerosene enters the float chamber through the float valve controlled by a metallic float. From the float chamber the fuel passes through a hole regulated by a needle-valve, to the spraying nozzle. When leaving this nozzle the fine spray is mixed with a small amount of air entering through the primary tube and is drawn up the heated vapor tube where it is completely vaporized and forms an extremely rich vapor. The heated vapor then passes through the shifter valve and enters the mixing chamber at the choke tube; there it is mixed with the balance of the air drawn through the main air tube. The mixture is then in the proper proportion for perfect combustion and is sucked into the cylinders through the intake manifold. The volume of gas mixture entering the cylinders is regulated by the throttle valve just under the choke tube.

### What is meant by a "Lean" and a "Rich" mixture?

A lean mixture has too much air and not enough fuel. A rich mixture has too much fuel and not enough air. A rich mixture will not only quickly cover the cylinder, pistons and valves with soot, but will also tend to overheat the cylinders, and is likewise wasteful of the fuel. It will often choke the motor and cause misfiring at low speeds.

The mixture should be kept as lean as possible without the sacrifice of any of the power of the motor. Too lean a mixture will result in backfiring through the vaporizer, for the reason that the gas burns slowly in the cylinder, and is still burning when the inlet valve opens again, causing the gas in the intake manifold to ignite. A rich mixture is shown by a heavy exhaust smoke. Proper mixture will cause very little smoke or odor.

### What is the purpose of the Air Valve?

It is located at the top of the mixing chamber and automatically controls the quantity of air entering the vaporizer. It is so proportioned that while on its seat it admits the air necessary for idling and lifts gradually as the throttle valve is opened. It gives the correct proportion of air to the mixture at any speed and load.

### What is the purpose of the Exhaust Shunt Valve?

It is used to regulate the amount of heat necessary to vaporize the kerosene in the vapor tube. When the valve lever on the old type vaporizer is at the "On" position or the shunt valve latch on the new type vaporizer is up, the exhaust from the cylinder passes around the vapor tube giving the maximum heating effect. When the lever is shifted

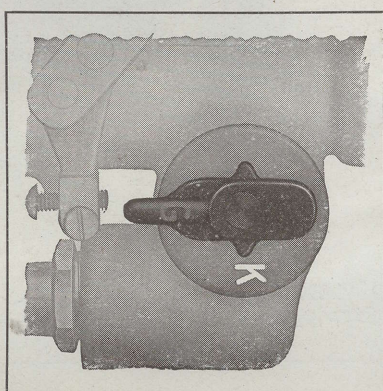

Shifter Valve on Kerosene—Plate No. 16

### Answer No. 59

### Answer No. 60

### Answer No. 61

### Answer No. 62

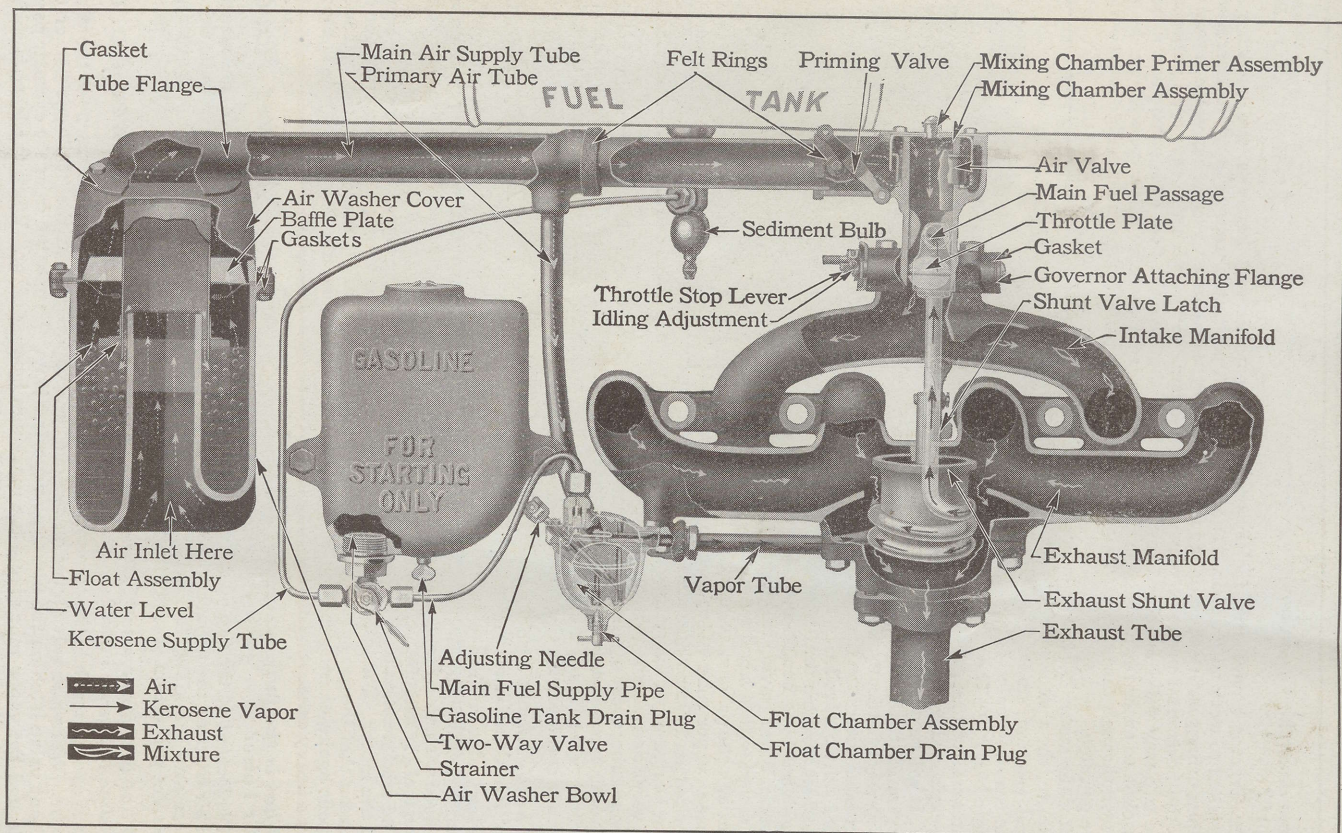

The Fuel System—Plate No. 17

to the "Off" position or the latch is down, the exhaust then passes through the center of the shunt valve and does not pass around the vapor tube. This gives a lower temperature to the mixture and should only be used when the Tractor is doing heavy pulling in hot weather. If the motor is left running without load the lever or latch must be shifted to the "On" position and the spark fully retarded, otherwise the motor will smoke and the spark plugs will get dirty.

**What is the purpose of the float?**

**Answer No. 63**

It automatically controls the flow of kerosene into the vaporizer. The float should close the valve when the kerosene reaches the proper level, indicated by a groove inside the float chamber. The level must not be above this line or more than one-eighth of an inch below.

**What makes the Vaporizer leak?**

**Answer No. 64**

The flow of kerosene entering the vaporizer through the fuel pipe is automatically regulated by the float valve raising and lowering on its seat. Should any particle of dirt become lodged in the seat, which prevents the valve from closing, the kerosene will overflow and leak out.

**How is the Vaporizer adjusted?**

**Answer No. 65**

The vaporizer has but one adjustment—the kerosene needle valve. The usual method of regulating is to start the motor on gasoline and run it for two or three minutes—keeping the shunt valve on the "Off" position. Turn down the needle valve lightly to its seat, then open it two and one-half turns. Turn the shifter valve on to kerosene, also shifting shunt valve lever to the "On" position, retard the spark lever to about the fourth notch and open the throttle until the motor is running at a good speed. The flow of kerosene should then be cut off by screwing the needle valve down to the right until the motor begins to misfire, then gradually increase the kerosene supply by opening the needle valve until the motor reaches its highest speed and no smoke comes from the exhaust. (This usually takes half a turn). After the best adjustment has been found the driver should observe the angle of the adjusting rod on the dash. In cold weather it will probably be found necessary to turn the adjusting rod one-quarter turn to the left, particularly before the motor has been thoroughly warmed.

**Can the Tractor be run on Gasoline instead of Kerosene?**

**Answer No. 66**

Yes, if desired gasoline can be used with results quite as good as those obtained when using kerosene. It should, however, be put into the fuel tank and used in exactly the same manner as kerosene. Running the tractor for a period of more than five minutes from the small gasoline tank may burn out the vapor tube. When running the Tractor on gasoline, always have the shunt valve on "Off" position.

**When there is water in the Vaporizer—What?**

**Answer No. 67**

The presence of water in the gasoline or kerosene tank, even in small amounts, will prevent easy starting and may cause the motor to misfire and stop. As water is heavier than either gasoline or kerosene, it settles to the bottom of the tank and into the sediment bulb. It is advisable to frequently drain the sediment bulb under the kerosene tank and also the gasoline tank by removing the pipe plug in the bottom.

During cold weather the water which accumulates in the sediment bulb may freeze, preventing the flow of kerosene to the vaporizer. Should this happen, wrap a cloth around the sediment bulb and keep it saturated with hot water for a short time. The water should then be drained off. In the event of water getting down into the carburetor and freezing the same treatment may be applied.

**When there is dirt in the Vaporizer—What?**

**Answer No. 68**

The gasoline passage in the shifter valve being very small a minute particle of grit or other foreign matter will clog up the hole and prevent the motor from starting. Should



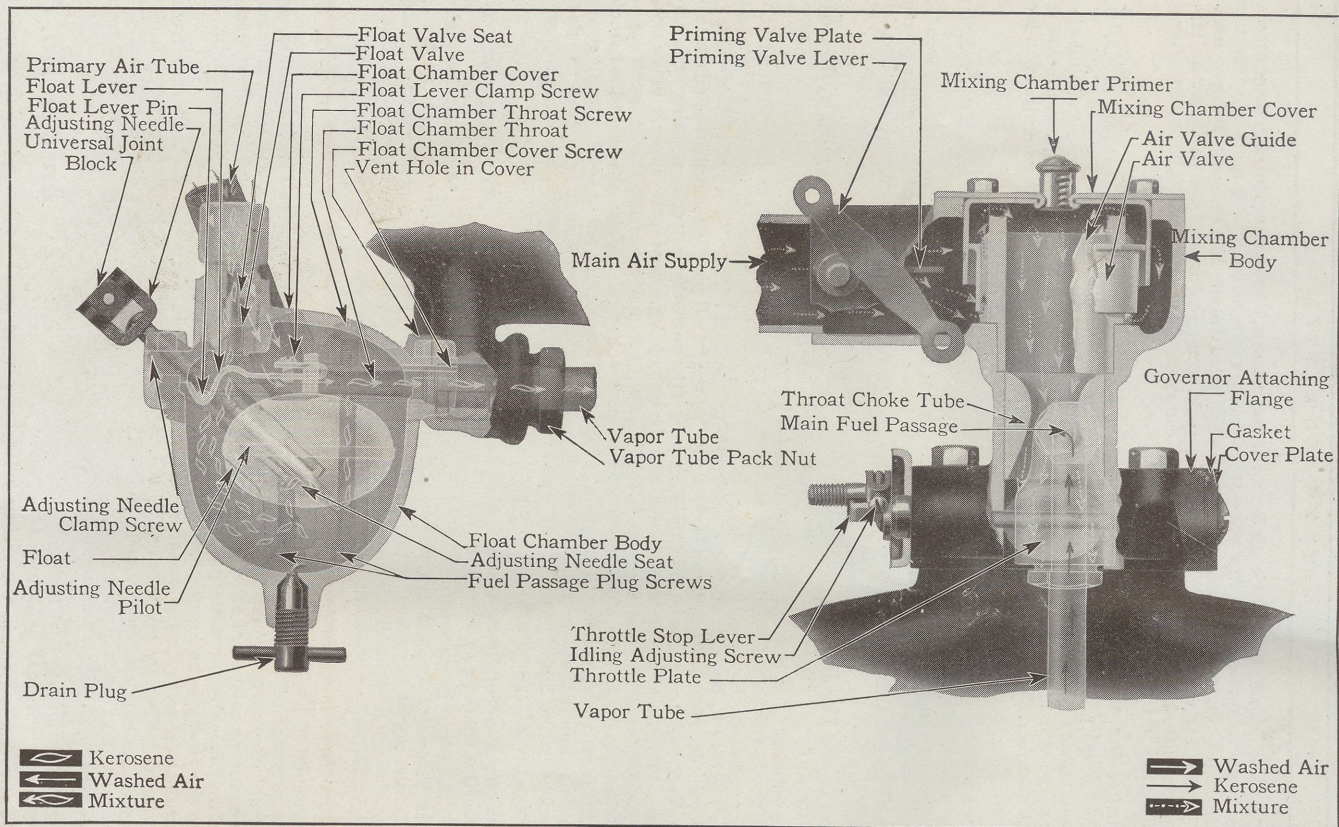

Float Chamber

Plate No. 18

Mixing Chamber

this occur, remove the shifter valve cover, set the valve in the gasoline position and insert a fine (shipping tag) wire through the passage. Should dirt get into the kerosene it may clog the spraying nozzle, causing the motor to misfire and slow down. The nozzle can be taken out and cleaned by removing the plug which screws into the float chamber just under the nozzle.

**If Motor runs too fast or chokes with Throttle retarded—What?**

**Answer No. 69**

If the motor runs too fast with throttle fully retarded, unscrew the throttle lever adjusting screw until the motor idles at suitable speed. If the motor chokes and stops when the throttle is fully retarded the adjusting screw should be screwed in until it strikes the boss, preventing the throttle from closing too far. When proper adjustment has been made, tighten the lock screw so that the adjustment will not be disturbed.

### The Ignition System

**What is the purpose of the Ignition System?**

**Answer No. 70**

It furnishes the electric spark which explodes the charge in the combustion chamber, thus producing the power which runs the motor. It is important that the charge be correctly ignited at the proper time, in order to obtain satisfactory results in running the motor. The spark lever placed on the dash controls this igniting at the proper time.

**How does the Magneto generate the Current?**

**Answer No. 71**

The magneto is an integral part of the motor, consisting of two sections, one attached to and rotating with the flywheel, and the other fastened to the cylinder casting. In revolving at the same rate of speed as the motor, the sixteen magnets on the flywheel passing the stationary coil spools create an alternating low tension electric current in coils of wire which are wound around spools fastened to the stationary part of the magneto, and is carried from these coils to the magneto connection wire leading to the coil box on the side of the motor. (See Plate No. 20.)

**How is the Coil Vibrator adjusted?**

**Answer No. 72**

The coil unit is properly adjusted when it leaves the factory and should not be disturbed unless to install new points or to reduce the gap between the points, which may have increased from wear. If the points are pitted, they should be carefully filed flat with a fine double-faced file and the adjusting nut turned down so that when the spring is held down the gap between the points will be a trifle less than  $\frac{1}{32}$  of an inch. Then set the lock nut so that the adjustment cannot be disturbed. Do not bend or hammer on the vibrators as this would affect the operation of the cushion spring on the vibrator bridge and reduce the efficiency of the coil. (See Plate No. 19.)

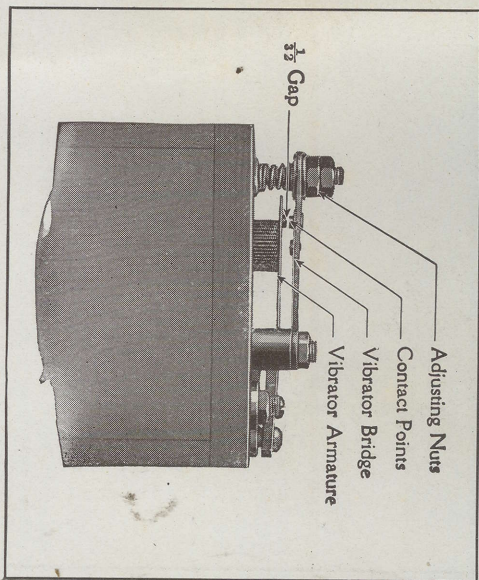

Coil Vibrator—Plate No. 19

**How is a Weak Unit detected?****Answer No. 73**

With the vibrators properly adjusted, if any particular cylinder fails to fire or seems to develop only a weak action, change the position of the unit to determine if the fault is actually in the unit. One symptom of a defective unit is the buzzing of the vibrator with no spark at the plug. Remember that a loose wire connection, faulty spark plug or worn commutator may cause irregularity in the running of the motor. These are the points that should be considered before laying the blame on the coil.

**How may short-circuit in Commutator Wiring be detected?****Answer No. 74**

Should the insulation of the primary wires (running from the coil to commutator) become worn to such an extent that the copper wire is exposed—the current will leak out (i. e., short-circuit) whenever contact with the cylinder block or other metal parts is made. A steady buzzing of one of the coil units when the motor is running will indicate a "short" in the wiring. When driving the tractor the motor will suddenly lag and pound on account of the premature explosion. Be careful not to crank the motor downward against compression when it is in this condition, as the "short" is apt to cause a vigorous back-fire.

**Does the Coil Adjustment affect starting?****Answer No. 75**

Yes. When the vibrators are not properly adjusted more current is required to make and break the contact between the points. As a result, at cranking you do not get a spark between the spark plug points. Do not allow the contact points to become "ragged," otherwise they are apt to stick and cause unnecessary difficulty in starting and when running they may cause an occasional "miss" in the motor.

**What is the purpose of the Commutator?****Answer No. 76**

The commutator (or timer) determines the proper instant at which the spark plugs must fire. It effects the "make and break" in the primary circuit. The grounded wire on the magneto allows the current to flow through the metal parts to the metal roller in the commutator. Therefore, when the commutator roller in revolving touches the four commutator contact points, to each of which is attached a wire connected with a coil unit, an electrical current is passed through the entire system of primary wires. This circuit is only momentary, however, as the roller passes over the contact point very rapidly, it will let in the current in each unit as the roller touches the contact point connected with that unit. The commutator should be kept clean and well oiled at all times.

**What about the Spark Plugs?****Answer No. 77**

One is located at the top of each cylinder and can easily be taken out with a spark plug wrench after the wire connection is removed. The high voltage current flows from the secondary coils in the coil box, and in reaching the contact points in each spark plug it is forced to jump a  $\frac{3}{8}$  of an inch gap, therefore forming a spark which ignites the charge in the cylinders. If the spark plugs become carbonized or sooted, the high tension current instead of jumping between the points of the spark plugs will pass through the carbon accumulation directly to the metallic shell. This will cause the cylinder to misfire. When in this condition the plugs should be removed and cleaned. (See Answer No. 39.)

**What are the indications of Ignition trouble?****Answer No. 78**

The uneven sputter and bang of the exhaust means that one or more cylinders are exploding irregularly or not at all, and that the trouble should be promptly located and overcome. Mishmish, if allowed to continue, will in time injure the motor and entire mechanism. A good driver will be satisfied only with a soft, steady purr from the exhaust. If anything goes wrong, stop and fix it immediately if possible.

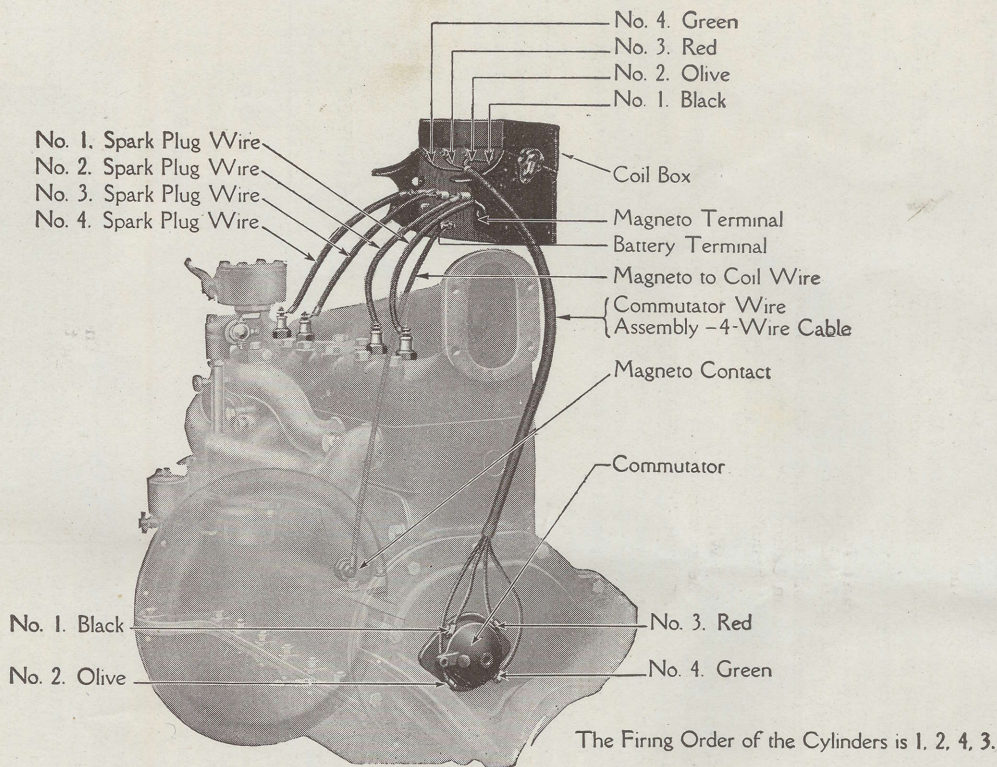

The Wiring System—Plate No. 20

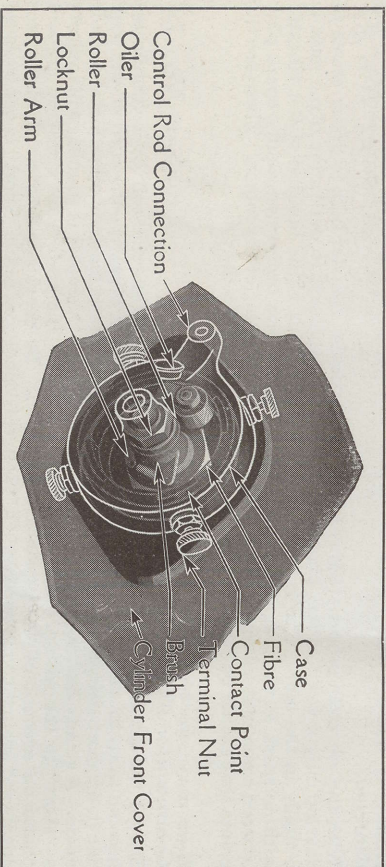

The Commutator—Plate No. 21

### How can one tell which Cylinder is Missing?

This is done by manipulating the vibrators on the spark coils. Open the throttle until the motor is running at a good speed, and then hold down the two outside vibrators (No. 1 and No. 4) with the fingers so they cannot buzz. This cuts out the two corresponding cylinders (No. 1 and No. 4), leaving only No. 2 and No. 3 running. If they explode regularly it is obvious the trouble is either in No. 1 or No. 4. Relieve No. 4 and hold down No. 2 and No. 3, and also No. 1; if No. 4 cylinder explodes evenly it is evident the misfiring is in No. 1. In this manner all of the cylinders in turn can be tested until the trouble is located. Examine both the spark plugs and the vibrator of the missing cylinder.

### If the Coil and Plugs are right what else might cause misfiring?

The trouble is probably due to an improperly seated valve, worn commutator, or short-circuit in the commutator wiring. Weakness from the valves may easily be determined by lifting the starting crank slowly the length of the stroke of each cylinder in turn, a strong or weak compression in any particular cylinder being easily detected. It sometimes happens that the cylinder head gaskets (packing) become leaky, permitting the gas under compression to escape, a condition that can be detected by running a little lubricating oil around the edge of the gasket and noticing whether bubbles appear or not.

### Does a worn Commutator ever cause misfiring?

Yes. If misfiring occurs when running at high speeds, inspect the commutator. The surface of the circle around which the roller travels (see Plate No. 21) should be clean and smooth, so that the roller makes a perfect contact at all points. If the roller fails to make a good contact on any one of the four contact points, its corresponding cylinder will not fire. Clean these surfaces, if dirty. In case the fibre contact points and roller of the commutator are badly worn, the most satisfactory remedy is to replace them with new parts. The spring should be strong enough to make a firm contact between the roller points even if they are worn or dirty.

### How is the Commutator removed?

Remove cotter pin from commutator control rod and detach latter from commutator. Loosen the nut which holds the commutator spring to the stud; this will release the commutator case, and this part can be readily removed. Unscrew lock nut; withdraw steel brush cap and lift out the retaining pin. The brush can then be removed from the camshaft.

### Answer No. 79

### Answer No. 80

### Answer No. 81

### Answer No. 82

In replacing the brush care must be exercised to see that it is replaced so that the exhaust valve on the first cylinder is closed when the brush points upward. This may be ascertained by removing the valve cover and observing the operation of No. 1 valve. In replacing commutator case be careful to see that the lug connection points towards the right-hand side of the Tractor and is horizontal. If the wires have been disconnected, be careful to replace them in the correct order. (See Plate No. 20.) It is better to remove wire and commutator case together.

### Does cold weather affect the Commutator?

### Answer No. 83

It is a well-known fact that in cold weather even the best grades of lubricating oil are apt to congeal to some extent. If this occurs in the commutator, it is possible that it may prevent the roller from making perfect contact with the segments embedded in the fibre. This, of course, makes difficult starting, as the roller arm spring is not stiff enough to brush away the film of oil which naturally forms on the contact segment surface. To overcome this, we recommend a mixture of 25 per cent kerosene with the commutator lubrication oil, which will thin it sufficiently to prevent congealing or freezing. Probably in starting the motor in cold weather only one or two cylinders will fire for the first minute or so, which indicates that the timer is in the condition described above and as a consequence a perfect contact is not being made on each of the four segments.

### How is the Magneto removed?

### Answer No. 84

(1) Disconnect the motor from the rear of the Tractor. (See Answer No. 42.) (2) Remove crank case. (3) Remove the six nuts from the studs holding the flywheel to the crank shaft. (4) Remove flywheel. You will then have access to the magneto and entire magneto mechanism. In taking out these parts or any parts of the Tractor, the utmost care should be taken so that the parts are so marked that they may be replaced properly.

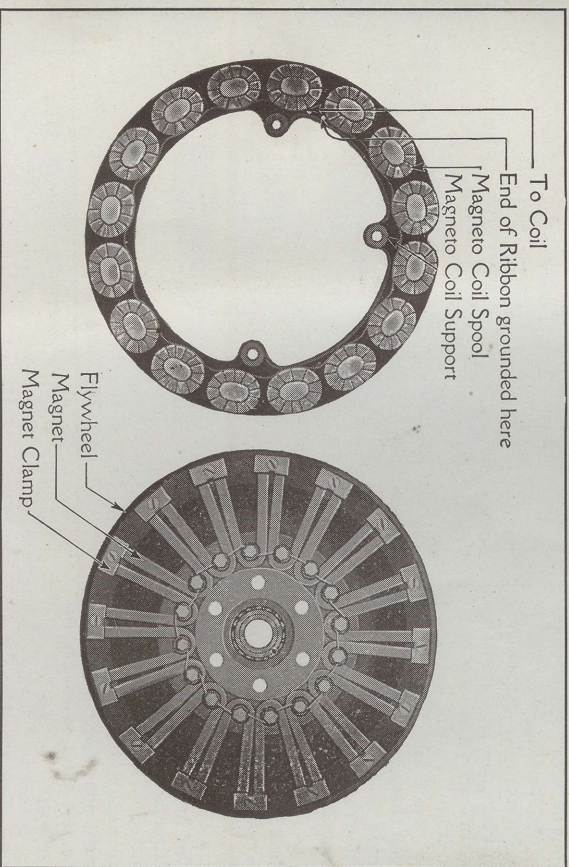

The Magneto—Plate No. 22

### When the Magneto gets out of order—What?

### Answer No. 85

The magneto is made of permanent magnets and there is very little likelihood of their ever losing their strength unless acted upon by some outside force. For instance, the

attachment of any electrical battery to the magneto terminal will demagnetize the magnets. Should this occur, it is not advisable to try to recharge them but rather install a complete set of new magnets. When using an electric battery for starting, be sure and disconnect the wire from the primary contact terminal.

The new magnets will be sent on a board in exactly the same manner as they should be when installed, so they will not stick together when in position on the flywheel. Great care should be taken in assembling the magnets and lining up the magneto, so that the faces of the magnets are even and are separated from the surface of the coil spool by  $\frac{1}{32}$  of an inch. The magneto is often blamed when the trouble is a weak current caused by waste or other foreign matter accumulating under the magneto contact spring, which is screwed into the side of the cylinder block; this should be taken out and the foreign substance removed.

## The Transmission

**Answer No. 86**

**What is the function of the Transmission?**  
It is that part of the Tractor which lies between the motor and the rear axle. It is the device by which the Tractor is enabled to move at different speeds to suit the various working conditions, and by it the Tractor is reversed.

**Answer No. 87**

**How does the Transmission operate?**  
By moving the sliding gears on the two transmission shafts it brings different sets of gears into action. Four different speeds can be obtained, three forward and one reverse. As shown on Plate No. 24 the gears are in the neutral (central) position. In this position no power is transmitted, even though the clutch is engaged. It is from this position that all gear changes are made.

The four views on Plate No. 25 show clearly the different working positions of the sliding gears and the sets of gears they engage. The heavy line indicates the path of the power transmitted. The gear changes are made by the movement of the gear shifter lever on the left-hand side of the Tractor.

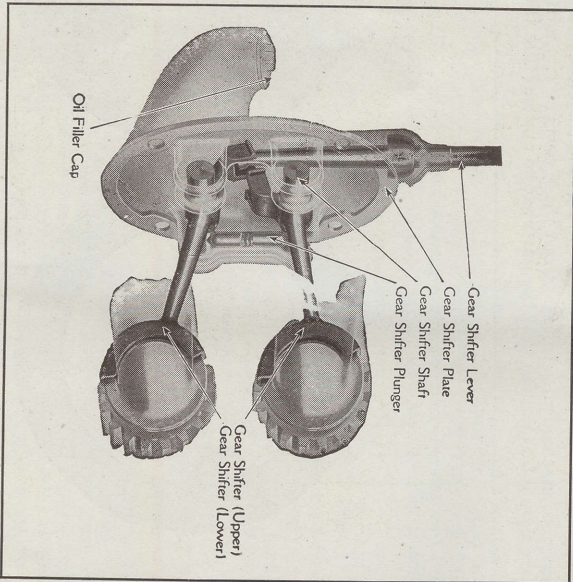

The Gear Shifter Assembly—Plate No. 23

**Answer No. 88**

**How does the Gear Shifter operate?**  
It is bolted to the side of the transmission housing and is fitted with two gear shifters which hold in place the sliding gears on the upper and lower transmission shafts. The gear shifter lever when moved sideways—from the neutral position—fits into the end of either the upper or lower gear shifter. (See Plate No. 23.) By moving the lever when it

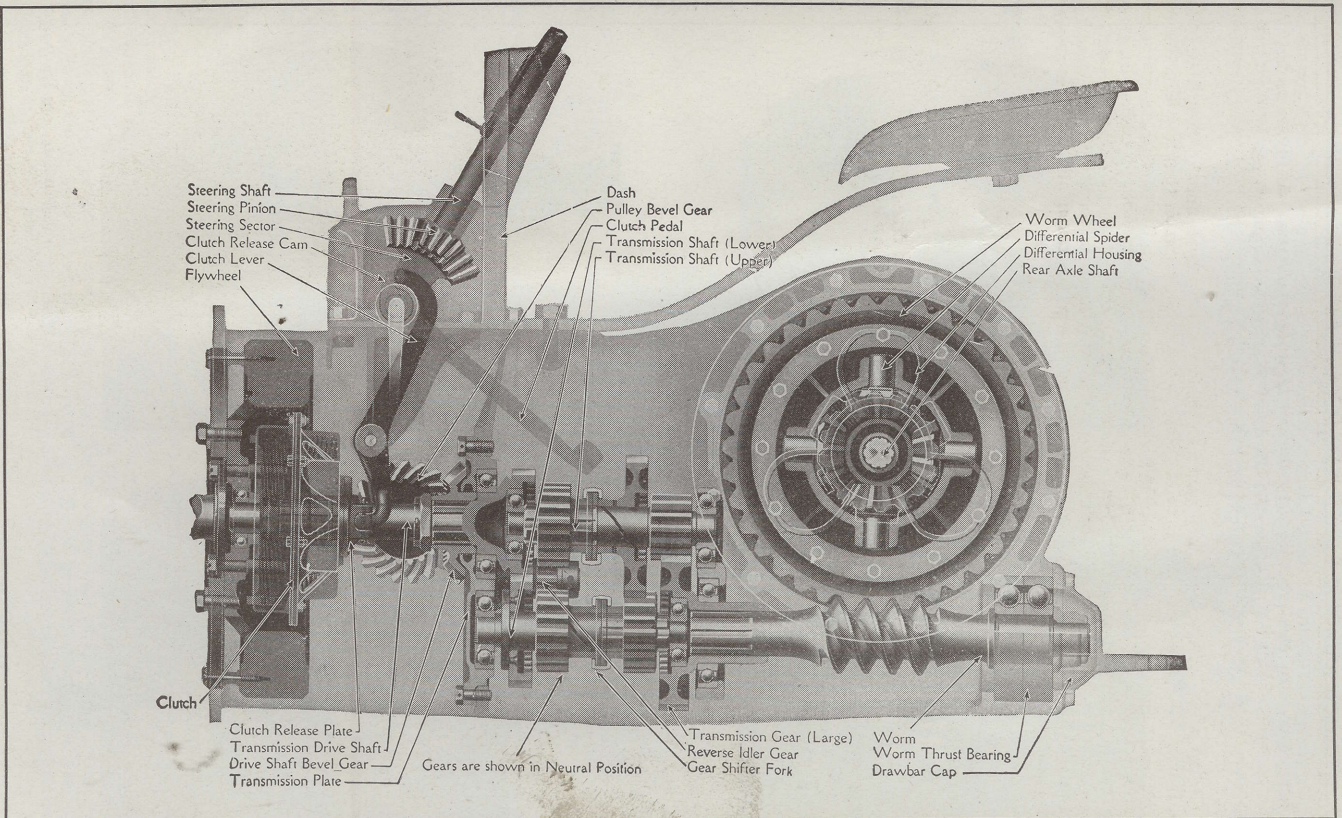

The Fordson Transmission and Clutch Assembly—Plate No. 24

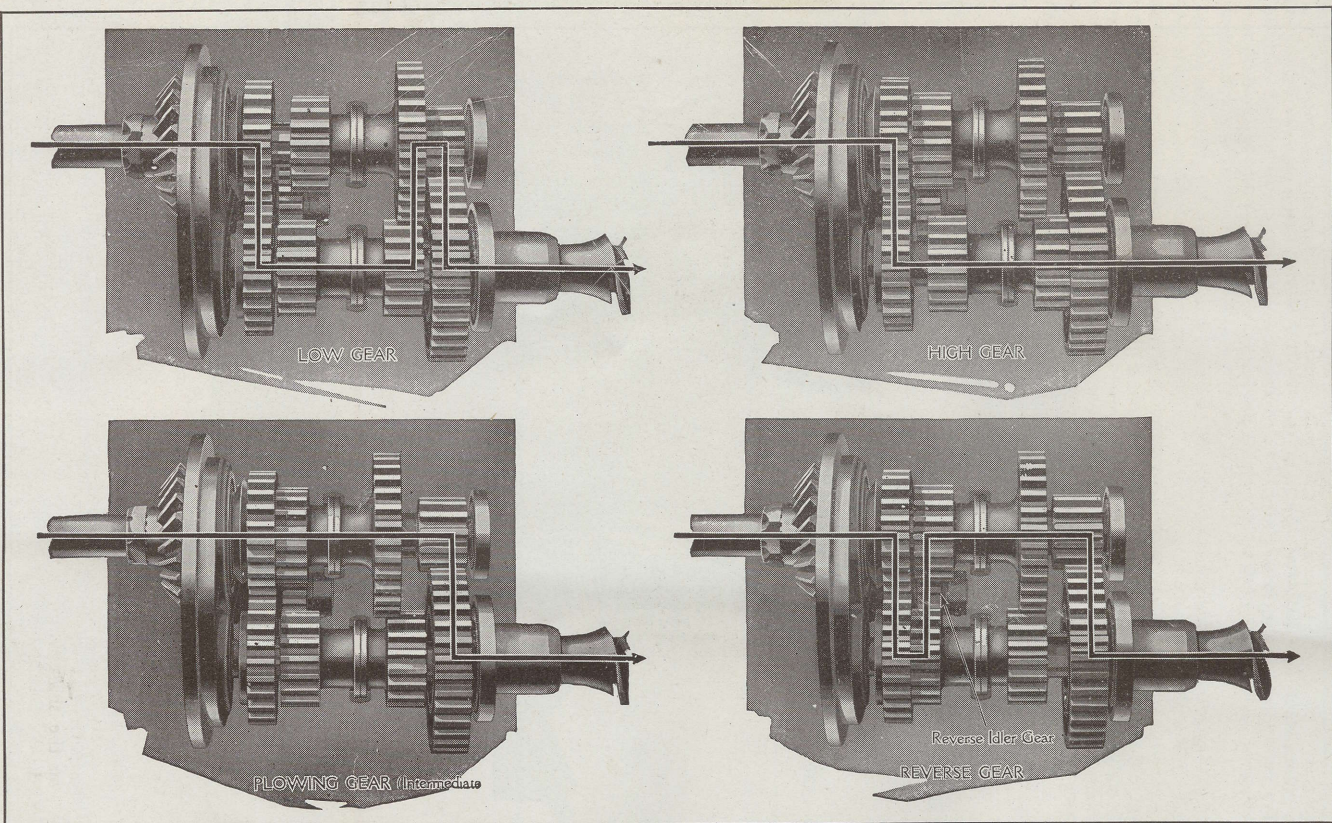

View Showing the Four Positions and Different Sets of Gears that are Engaged—Plate No. 25

is so placed it slides the gears along the shaft causing them to mesh. A spring plunger holds the gear shifters in the position to which they are shifted while an interlocking pin prevents accidental engagement of more than one set of gears.  
**DO NOT ATTEMPT TO SHIFT GEARS BEFORE DISENGAGING THE CLUTCH.**

*What attention does the Transmission require?*

**Answer No. 89**

As the transmission gears are hardened and the shafts run on ball bearings, there will be practically no wear if they are kept free from grit and well supplied with a good grade of oil. No adjustments are provided or are necessary. If the bronze bushing in the reverse gear wears in time, it should be replaced by a new bushing. If an attempt is made to change gears without first disengaging the clutch it will chip or break the ends of the gear teeth. Should this happen, the transmission should be taken apart and washed out with kerosene to remove any particles of steel which would damage the gears or bearings.

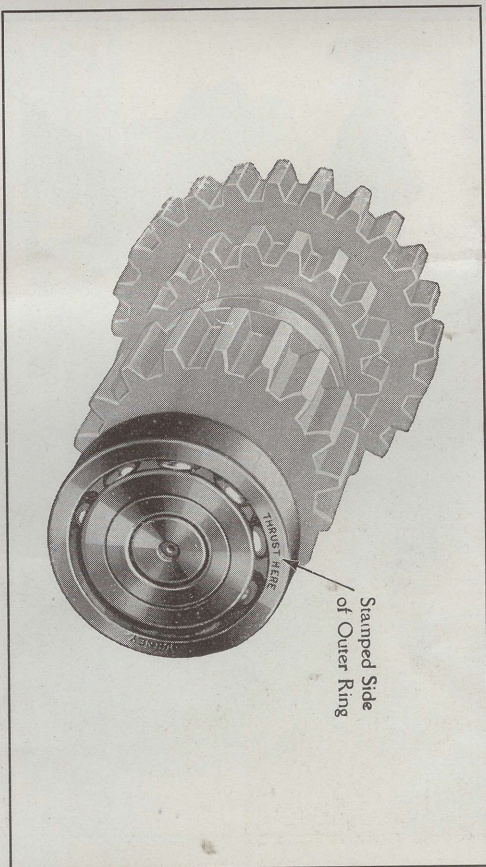

Replacing Ball Bearings—Plate No. 26

*How are the Transmission Gears removed?*

**Answer No. 90**

After removing the rear half of the Tractor from the m.c. or as described in Answer No. 42, proceed as follows: (1) Drain the oil from the transmission housing by removing the drain plug just under the gear shifter cover. (2) Remove the gear shifter cover by unscrewing the four cap screws holding it to the transmission housing. (3) Unscrew the clutch drum nut from the end of the transmission drive shaft and draw off the clutch. (4) Remove the eight cap screws holding the transmission plate; then by pulling on the drive shaft, the plate together with the lower transmission shaft can be removed from the housing in one unit. (See Plate No. 28.) (5) Remove the upper transmission shaft with its gears.

Before replacing the gears in the housing clean them well with kerosene; the housing should also be flushed out with kerosene to remove any grit or gummed oil. Also clean and examine all ball races. If it has been found necessary to remove the ball bearings, be very careful in assembling them on the shafts again, that they are replaced in exactly the same position as before removing: i. e., the stamped face of the outer rings must face towards the ends of the shaft. (See Plate No. 26.) The inner ring of the bearing is pressed on the shaft while the outer ring slips into its seat when the parts are being assembled.

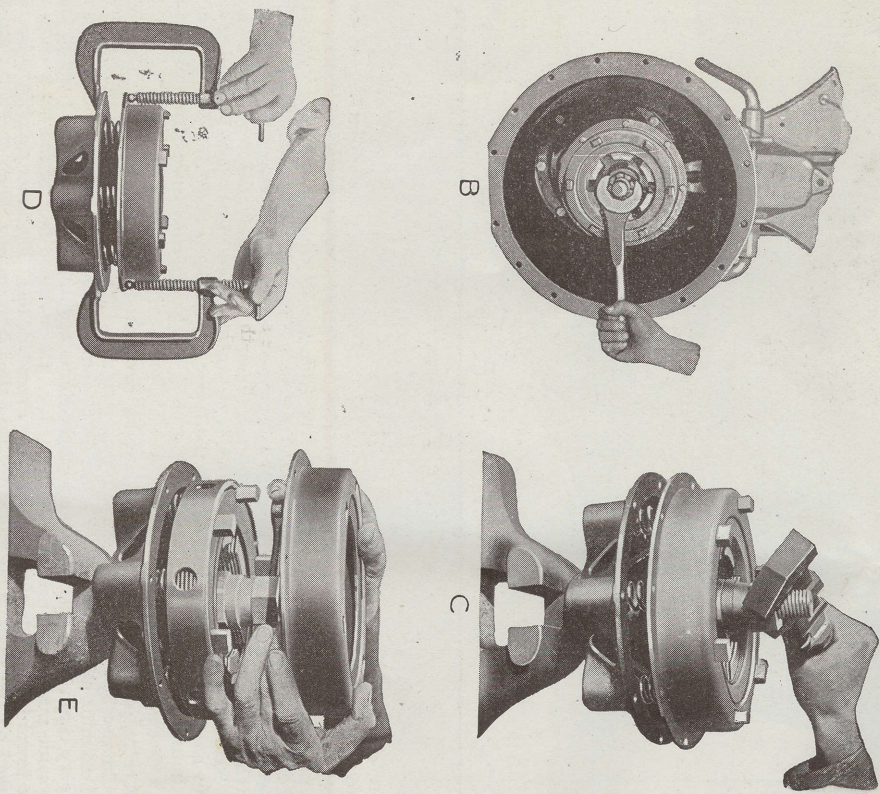
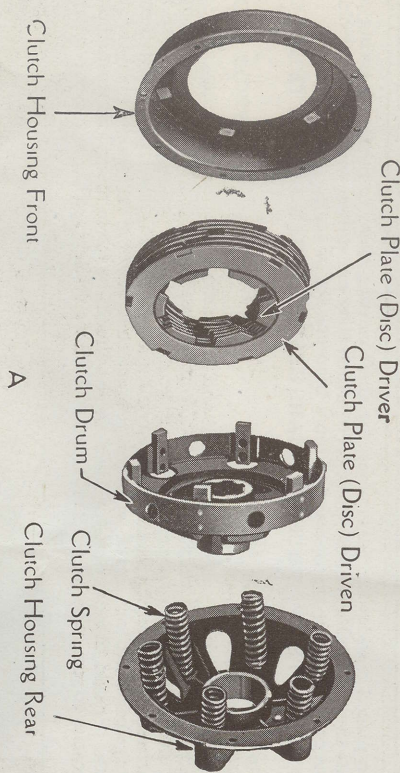

Clutch Parts and Assembly Methods—Plate No. 27

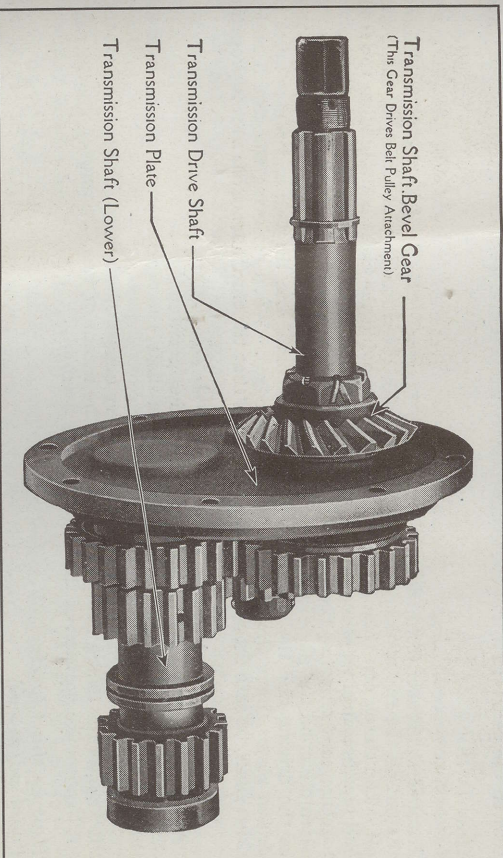

Showing the Transmission Plate and Gears as they are removed in one unit—Plate No. 28

## The Clutch

**What is the purpose of the Clutch?**

If the motor was connected directly to the transmission and through it to the rear wheels, it would be impossible to engage or disengage the gears without breaking the teeth. To overcome this difficulty the motor is connected to the transmission drive shaft by means of the clutch, the frictional engagement of which allows the motor to pick up its load gradually and start the Tractor without jolt or jar.

**Answer No. 91**

**How does the Clutch operate?**

By the frictional engagement between two sets of plates, forced together by springs. The driving set of plates fit on six studs fixed in the flywheel; the set of driven plates fit six keys in the clutch drum which is fixed on the drive shaft. When the clutch is engaged—by allowing the clutch pedal to rise—the six springs force all the plates together, the resulting friction causing them to revolve as one solid unit. When the clutch is disengaged—by pressing down on the clutch pedal—the spring pressure on the plates is released, allowing them to slip past each other, thus permitting the motor to run free. Plate No. 27 (A) shows the relative assembling positions of these parts. The clutch is lubricated by the oil splashed up by the flywheel. No adjustment is necessary in the clutch. If it slips when working, it will be due to weak springs or worn plates and they should be replaced by new ones. If the clutch sticks and does not release easily it should be taken apart and examined; bent clutch plates usually cause this trouble. If any of these be found they should be removed and replaced by new ones.

**Answer No. 92**

**How is the Clutch controlled?**

By the pedal on the right-hand side of the Tractor. It acts on the clutch release plate causing the clutch housing to move in a forward direction. This releases the spring pressure from the clutch plates.

**Answer No. 93**

After engaging gears always let the pedal rise gently and when driving do not rest your foot on the pedal, as it will cause unnecessary friction and wear the clutch release plate.

**How is the**

**Clutch removed?**

Remove the motor from the rear part of the Tractor. (See Answer No. 42.) Remove the nut on the end of the drive shaft which holds the clutch in place and pull the clutch off. The clutch can then be taken apart by removing the eight bolts holding the front and rear housings together. Some means should be provided for holding the two halves together and relieving the tension of the springs gradually. (See Plate No. 27.) In assembling, oil the plates well and be sure they are replaced in their proper order; that is, the driving and the driven plates must alternate, and the two end plates must be driven plates (have the slots on the outside edge). When replacing the clutch on the drive shaft, be sure the split ring is in place and that the clutch drum fits over it properly.

**Answer No. 94**

#### PLATE NO. 27

"A" shows the parts in their relative assembling position.

"B" shows the clutch in position on the drive shaft, the repairman tightening it to the shaft with a hexagon nut.

"C" shows the clutch being drawn together by means of a bolt.

"D" shows the clutch being drawn together by means of two C clamps.

"E" shows the position of the clutch during assembly.

**How is the Clutch Pedal adjusted?**

**Answer No. 95**

After the Tractor has been in use for some time the wear on the clutch release plate may cause the clutch pedal to strike the foot rest, before the clutch is fully disengaged. When this happens it can be adjusted in the following manner:

- (1) Remove the air washer.
- (2) Remove the dash.
- (3) Take out the pin holding the steering gear sector on the steering arm (inside the dash) and remove the steering arm.
- (4) The cam which fits on the end of the clutch pedal can now be removed.
- (5) Advance the cam one or two notches to the right and replace, being sure that the split ring, which it holds, is in place.
- (6) Try out the new position of the clutch pedal and if it is satisfactory replace the dash.

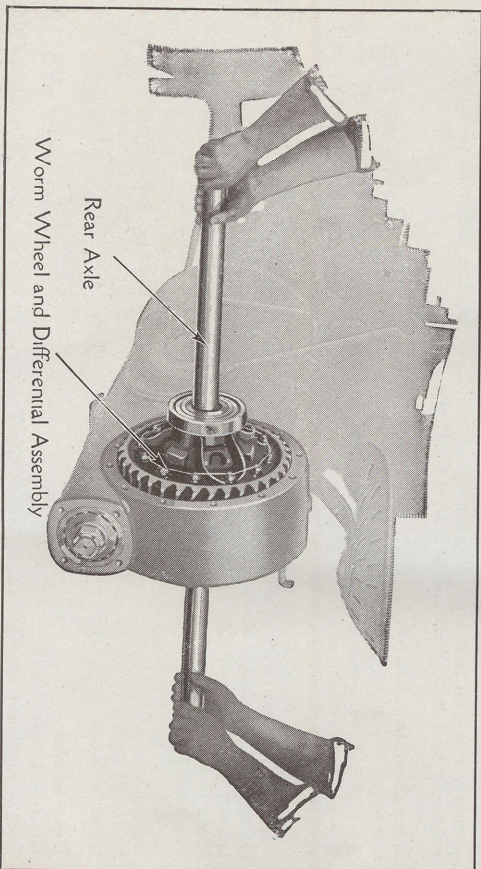

Removing Rear Axle Assembly—Plate No. 29

## The Rear Axle

**What about the Rear Axle?**

It applies the power, received through the transmission, to the rear wheels. The principal parts of the assembly are the worm and worm wheel, the differential, the axle shafts, and bearings. (See Plate No. 31.) It is lubricated by the same oil bath as the transmission.

**Answer No. 96**

**What is the purpose of the Differential?**

It is the set of bevel gears installed in the center of the rear axle and compensates for difference in speed of rotation of the two rear wheels when making a turn.

**Answer No. 97**

**How is the Rear Axle Assembly removed?**

**Answer No. 98**

(1) Drain the oil from the transmission housing. (2) Jack up the rear end of the Tractor and remove the rear wheels. (See Answer No. 100.) (3) Remove the twelve cap screws from each of the rear axle housings and draw them off. (4) The rear axles and differential can then be lifted out in one unit. (See Plate No. 29.) The worm wheel and differential housings can then be taken apart by removing the twelve bolts holding them together. The relative assembly positions of these parts is shown in Plate No. 32.

**How is the Differential Gear removed from the Rear Axle Shaft?**

**Answer No. 99**

(1) Press the gear back along the shaft until the split locking ring is exposed. (See Plate No. 33.) (2) Remove the ring and press the gear off the shaft.

**How are the Rear Wheels removed?**

**Answer No. 100**

(1) Jack up the rear axle until the wheel is clear of the ground. (2) Removing the four bolts from the hub using the box wrench and bar sent in the tool box. (3) Then insert two of the bolts in the tapped (threaded) holes of the rear wheel bushing, tighten up the bolts evenly until the wheel is free on the bushing. (See Plate No. 34.) (4) Apply the hooked end of the bar to the flange and force the bushing off the axle. When replacing the wheel, the four screws are inserted in their respective holes and tightened up equally; the ends of the rear axle being kept flush with the outside of the bushing.

**What attention do the Roller Bearings require?**

**Answer No. 101**

The roller bearings at each end of the rear axle housing should be well lubricated by occasionally removing the plugs and inserting heavy fluid gear oil. The felt washers which protect them from dust and dirt need replacing when dirty or badly worn. To do this remove the rear wheel. (See Answer No. 100.) The felt washer is inside the steel cover on the end of the housing. This can be removed as shown on Plate No. 30. When replacing the felt cover, the edge should be bent into the groove in the end of the rear axle housing, to prevent it from coming off.

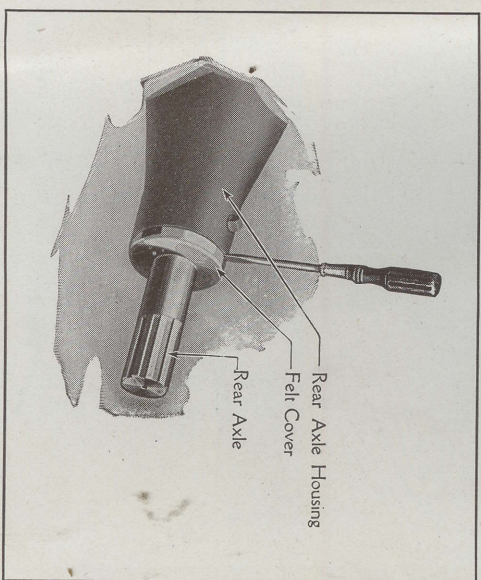

Removing Rear Axle Felt and Roller Bearing—Plate No. 30

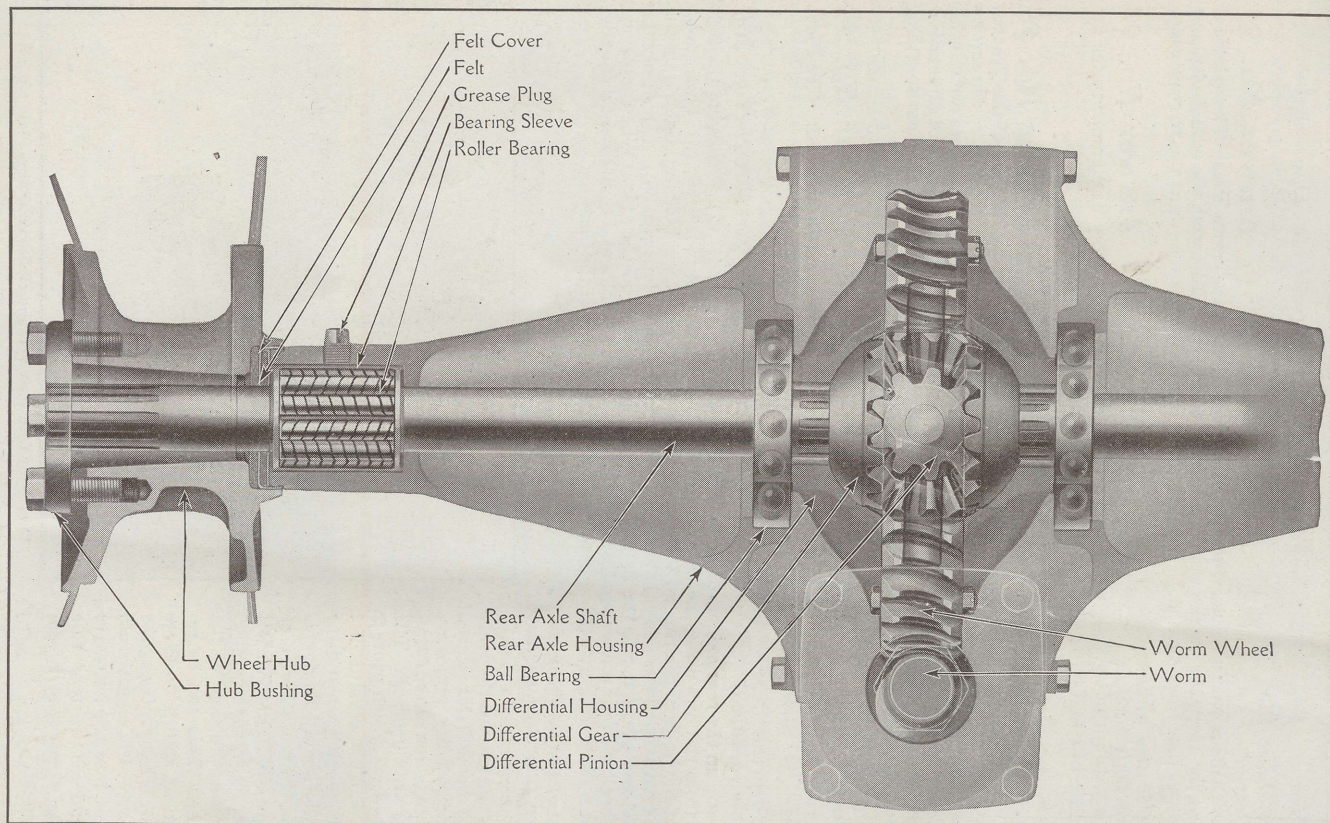

Rear Axle and Wheel Assembly—Plate No. 31

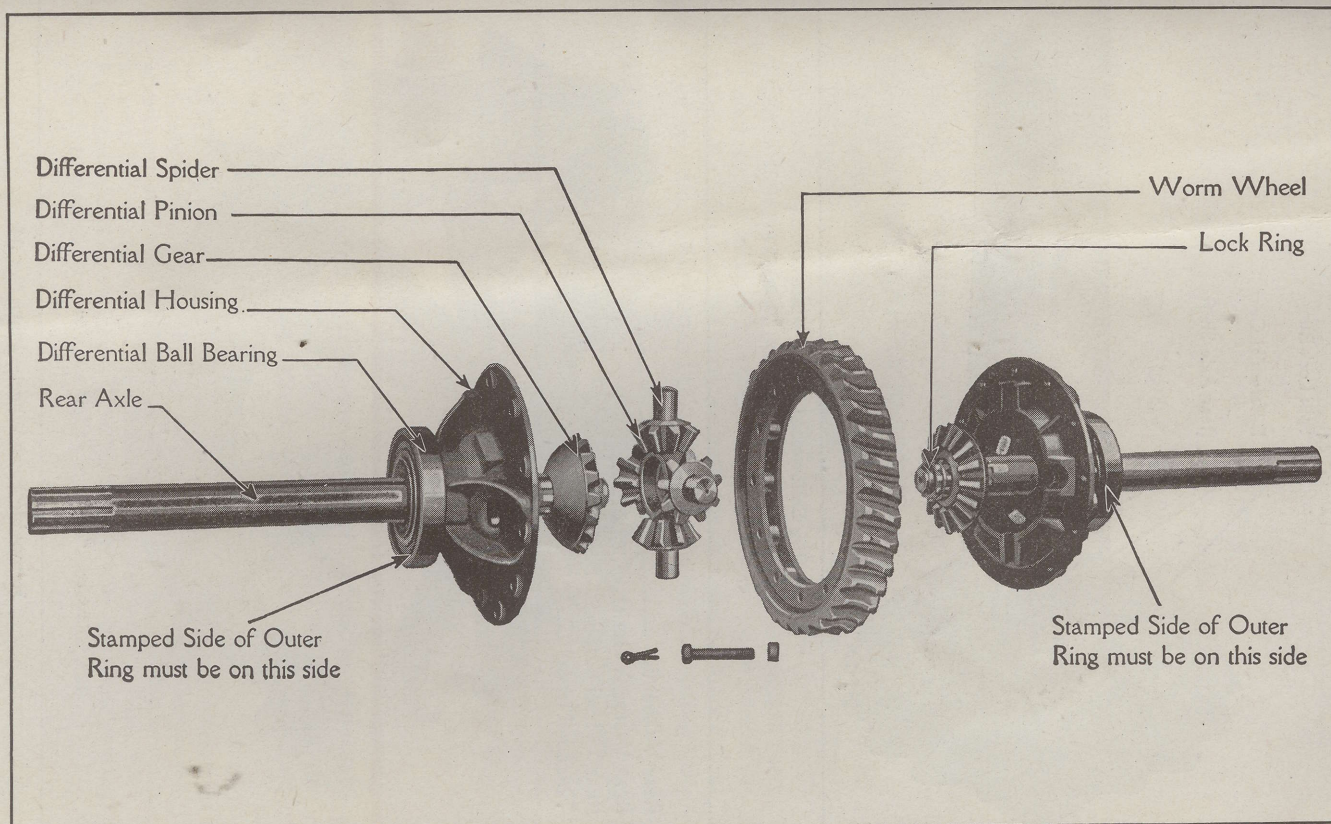

Differential and Rear Axle in their Relative Assembling Positions—Plate No. 32



*Instructions for*  
**Mounting Roller Bearings  
 on Front Wheels**

**FIT OF CONES AND CUPS**

The cups should be a good press fit in hubs and seated firmly against shoulder in hub. The cones should be a floating fit on spindle to allow cone to change position on spindle and not have all wear come on one point of cone. In no case should wheel cones have a tight fit on spindle.

**TO ASSEMBLE AND LUBRICATE**

Fill hub between cups and pack inner cone with good quality medium body cup grease, being sure space between rollers is filled with grease. Before putting wheel on spindle place inner cone in inner end of hub. Next install dust enclosure which is a tight fit in hub, then place wheel on spindle. Pack outer cone with grease and place on outer end of spindle. Put on tongued lock washer and adjusting nut.

**ADJUSTMENT**

Take adjusting nut up tight, so tight that wheel will bind, at same time revolve wheel to insure all working surfaces coming in contact, then back off adjusting nut  $\frac{1}{8}$  to  $\frac{2}{8}$  turn of nut, sufficient to allow wheel to rotate free but with no end play, then lock adjusting nut in this position with cotter key. Next put on hub cap filled with grease.

**TO REMOVE WHEELS**

Unscrew hub cap and remove all old grease from same. Take out cotter pin and unscrew nut. Remove wheel and inner cone, remove all old grease. Wash all parts thoroughly with kerosene and reassemble and lubricate per instructions above.

**CAUTION**—Care should be taken that no dirt or water gets on bearings or in hubs when wheels are being re-adjusted and lubricated. When making adjustment of front wheel bearings, do not mistake end play in bearings for loose motion of steering knuckle on steering knuckle bolt. When making adjustment place chisel or tapered bar between axle center and steering knuckle to hold steering knuckle rigid while making adjustment.

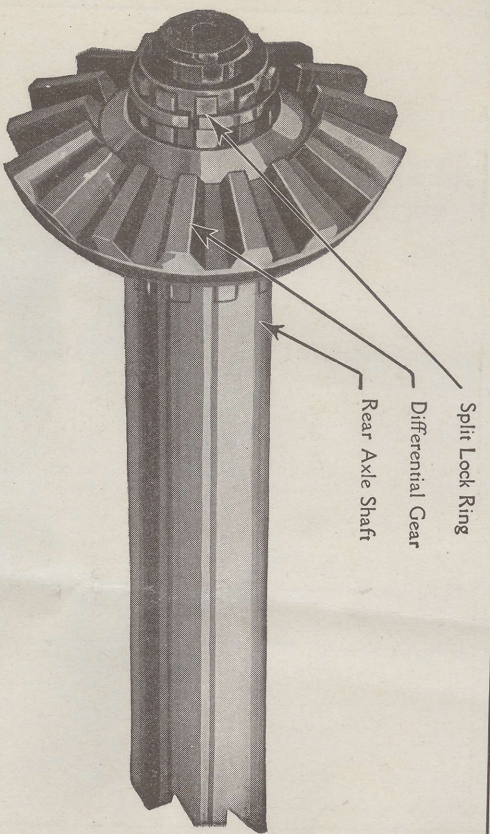

Removing Differential Gear—Plate No. 33

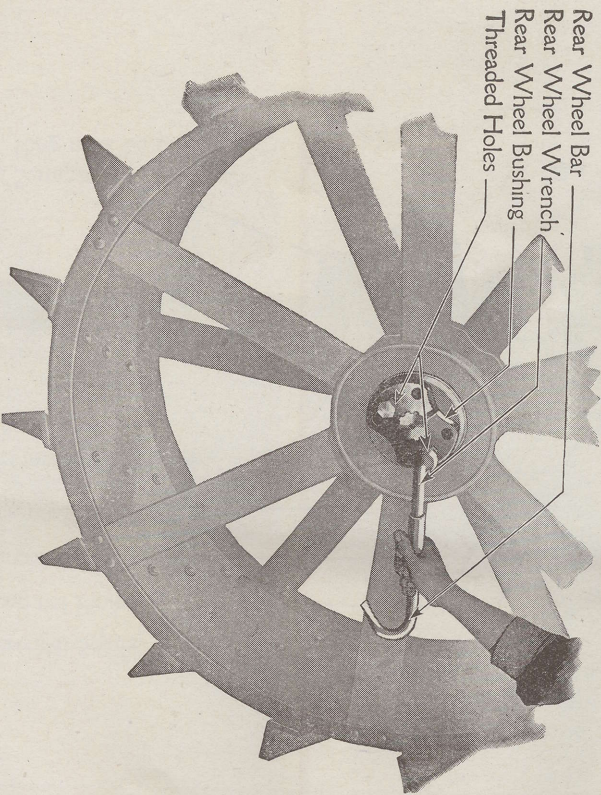

Removing Rear Wheel—Plate No. 34

## The Running Gear

*What attention should the Running Gear have?*

**Answer No. 102**

It should be carefully gone over every week to see that all bolts and connections are secure, and any looseness in the steering joints should be taken up. The working parts should be well lubricated at all times and kept free from dust and mud.

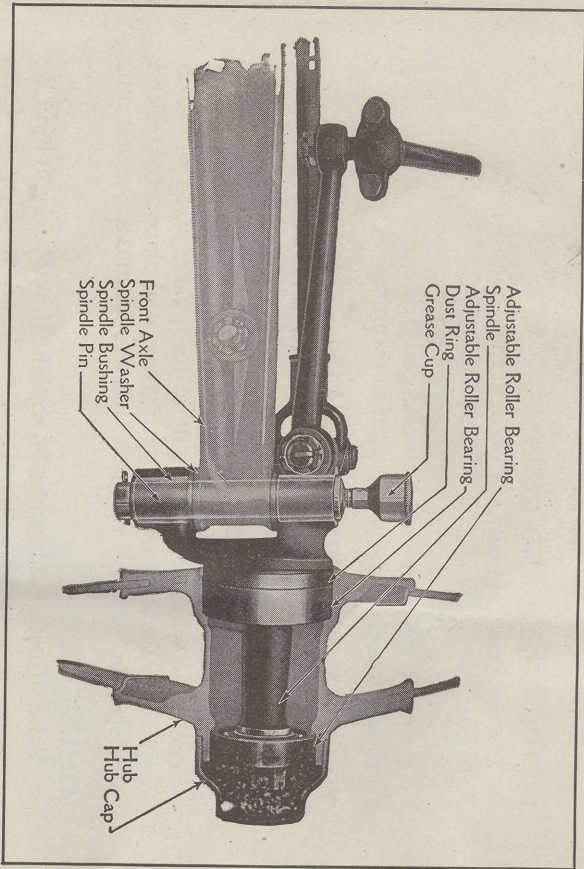

Front Wheel Spindle—Plate No. 35

**Answer No. 103**

*In case of accident how is the Front Axle straightened?*

Should the axle or spindle become bent, extreme care must be used to straighten the parts accurately. Do not heat the forgings, as this will distemper the steel, but straighten them cold. If convenient, it would be better to send such parts to a regular repair shop, where they may be properly straightened by fixtures designed for that purpose. It is very essential that the wheels line up properly, as improper alignments will cause defective steering and strain the parts.

*How is the Front Axle removed?*

**Answer No. 104**

Jack up front of Tractor so that wheels can be removed. (See Answer No. 105.) Disconnect steering drag link from the steering arm—rear. Disconnect radius rod from crank case. Remove the front axle trunnion pin and front axle.

*How are the Front Wheels removed?*

**Answer No. 105**

Take off hub cap, jack up front of Tractor, take out cotter pin and unscrew nut from end of wheel spindle. The wheels can then be drawn off along with the end roller bearing. The other roller bearing can then be removed, allowing the spindle washer to be taken off. Before replacing the wheel, clean hub and spindle with kerosene and then fill up the hub and cap with fresh grease. Be careful in replacing the roller bearings that the stamped faces of the outer rings face each other. (See Plate No. 35.)

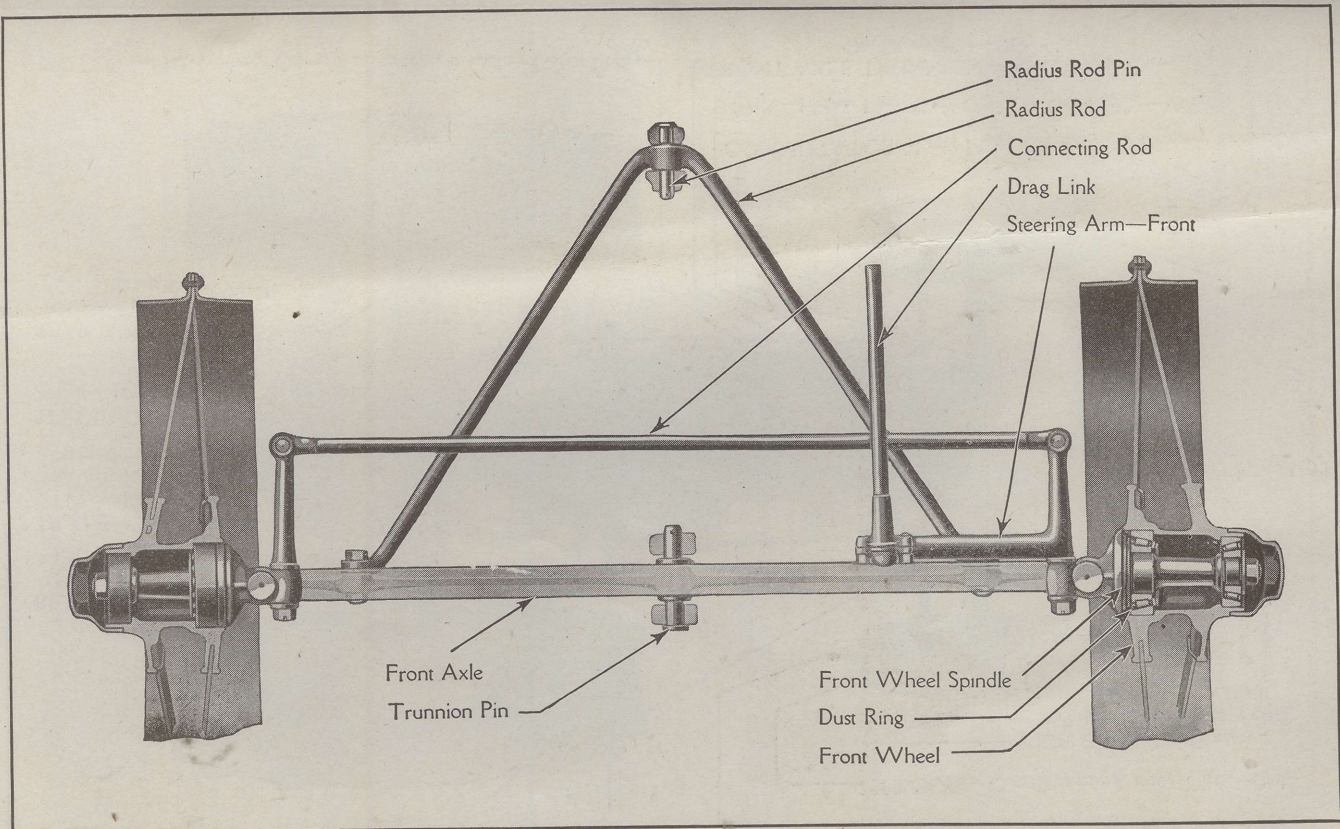

Front Axle and Wheel Assembly—Plate No. 36

**How is Steering Gear tightened?**

Should the steering gear become loose, that is, so that a slight movement of the wheel does not produce immediate results, it may be tightened in the following manner: Disconnect the two halves of the ball sockets which surround the steering arm ball and file off the surface until they fit snugly around the ball. If the ball is badly worn, replace by a new one. If the yoke pins in the steering spindle arms appear to be loose, the steel bushings should be replaced with new ones. The bushings in the front wheel spindle should also be replaced by new ones if the spindle pin is too loose. Excessive movement of the spindle in a vertical direction can be remedied by renewing the two spindle washers. (See Plate No. 35.)

**CAUTION**

Do not install the roller bearings on the old style spindle bodies. The new body has a groove in the thread end into which fits the tongue of the new style washer which is assembled between outer roller assembly and the nut.

**The Lubricating System**

**Answer No. 107**

**What attention does the Lubricating System require?**  
The most important feature in the maintenance of the Tractor is proper lubrication. This Plate No. 37 shows the points of lubrication, and specifies the attention required. This chart should be studied carefully and often. Only high-grade oils should be used and the instructions regarding times and kind of oil should be carefully followed. Frequent inspection and lubrication is essential to insure the proper running and long life of the Tractor.

**What about the Motor Lubrication?**

**Answer No. 108**

The oiling of the motor must be given close attention. Use only a Tractor lubricating oil of Ford specifications given on page 55. Oil conforming to these specifications has sufficient "body" so that the pressure between the bearing surfaces will not force the oil out and allow the metal surfaces to come in contact and to seal piston ring clearance. Inferior oils have a tendency to carbonize quickly, also to gum up the piston rings, valve stems and bushings.  
The motor is oiled by the splash system, from the oil reservoir in the crank case. (See Plate No. 6.) Oil should be added at least twice per day, and under no circumstances should the level be allowed to drop below the lower pet cock. It is best to test the oil level and fill the motor when it is warm. This will avoid the possibility of adding too much oil, as when cold the oil is sluggish and may not run freely out of the pet cock. If too much oil is put in the motor it will form carbon in the cylinders and also dirty the spark plugs. Also to further insure crankcase from dirt accumulations care should be taken to keep space about breather cap clean.

**How often should the oil in the Motor be changed?**

**Answer No. 109**

When a new Tractor has been driven a few days the oil in the crank case must be drained off and the motor refilled with entirely fresh oil. It will be necessary to repeat this operation every week if the Tractor is being used continuously.  
Remove the drain plug underneath the crank case and drain off the oil, flush out with a quart or so of kerosene to remove sediment and dirty oil, replace the plug and refill with fresh oil to the level of the top pet cock. The later tractors are provided with an oil sump. (See Plate No. 10.) The plug should be removed and this sump cleaned occasionally. The oil which is drained off the motor can be used to lubricate machinery around the farm, so that no oil is wasted.  
Whenever the motor is disassembled for repairs the opportunity should be taken to thoroughly clean out the oil pipe which is located in the upper half of the crank chamber.

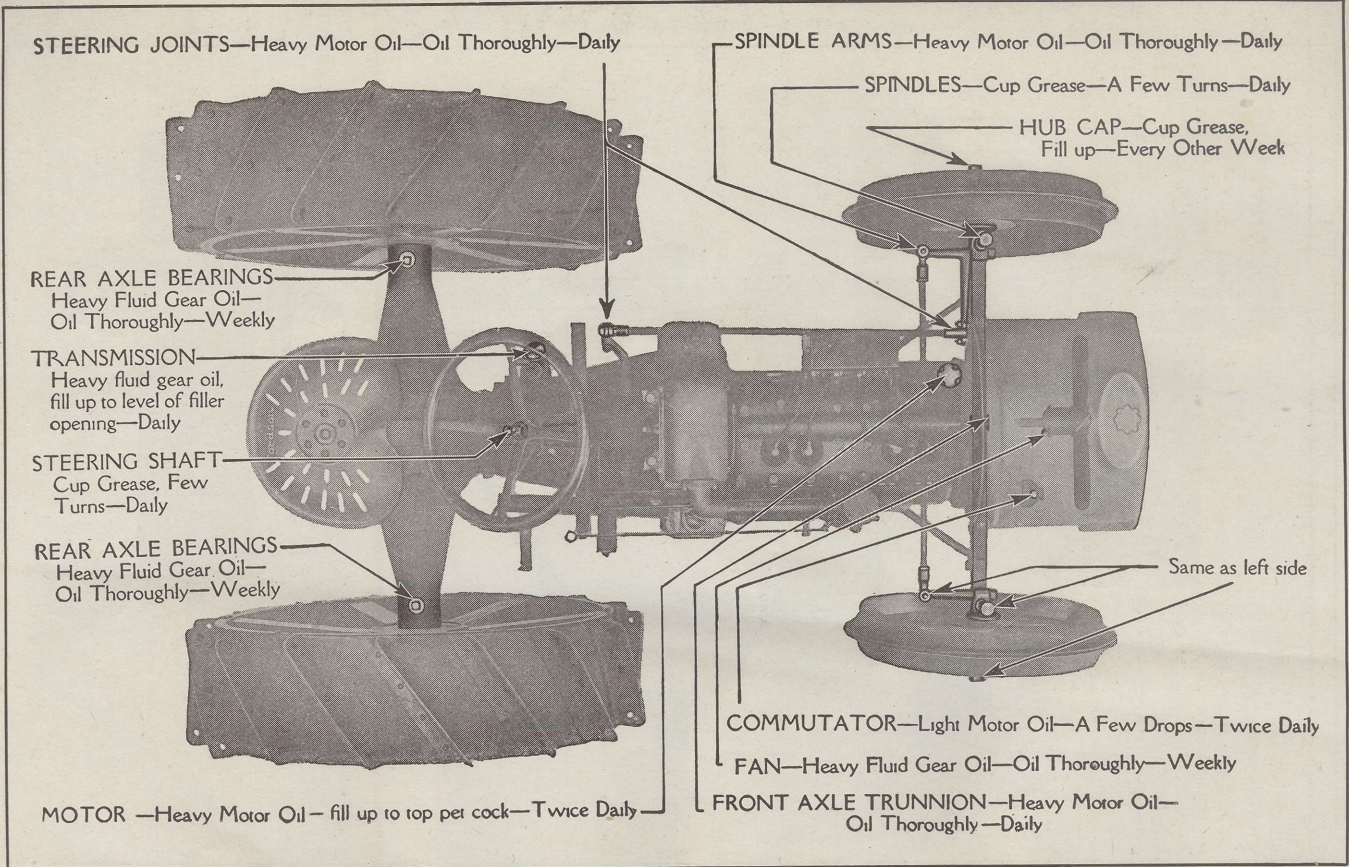

Tractor Lubrication Chart—Plate No. 37

**What about the Clutch and Steering Gear Lubrication?**

The clutch and steering gear are lubricated by the oil in the crank case which is thrown up by the flywheel. They receive a plentiful supply of oil and require no attention if the oil in the crank case is kept at the proper level.

**Answer No. 110****What about the Transmission and Rear Axle Lubrication?**

The transmission and rear axle are lubricated by a single oil bath in the transmission housing. Use only Tractor Lubricating oil of Ford specifications given on page 55. The oil level should be inspected twice a day. Add oil when the motor is warm. Be sure it has reached every part before replacing the filler cap. The oil should be poured in until it reaches the level of the filler cap hole. It is necessary to drain off the oil every two weeks and replace with fresh oil. Remove the drain plug underneath the housing, and after all oil has been drawn off, flush it out with a quart or so of kerosene. Replace the plug and refill with fresh oil. This operation should be done when the Tractor is warm, as the oil will then flow more readily.

**Answer No. 111**

Should the oil be left unchanged too long, or if a light oil is used, the transmission housing will become very warm when the Tractor is in use. This condition must be remedied immediately or excessive wear will be caused to the moving parts.

**How often should Commutator be oiled?****Answer No. 112**

Keeping the commutator well oiled is a matter of far greater importance than many drivers believe and is necessary in order to have a smooth operating motor. Do not be afraid to put a little oil into the commutator twice a day. Remember that the commutator brush revolves very rapidly, and without sufficient lubrication the parts soon become badly worn. When in this condition perfect contact between the brush and the four contact points is impossible, and as a result the motor is apt to misfire when running at a good rate of speed.

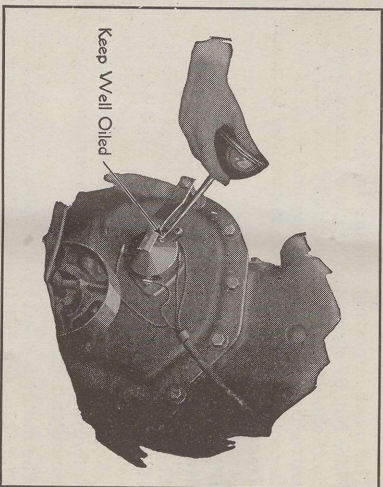

Oiling the Commutator—Plate No. 38

**Points on Maintenance****How about cleaning the Tractor?**

The Tractor should be kept free from rust or dust. If allowed to accumulate, it may in time get carried into the bearing surfaces and cause unnecessary wear. Wash the Tractor frequently and keep it well painted to prevent rusting. When washing, care must be taken that no water reaches the wiring coil box or spark plugs, as this would result in a short-circuit and failure of the ignition system.

The most important point in maintenance of a Tractor is proper and efficient lubrication and cleaning. Frequently inspect the Tractor. See that it is kept properly adjusted and that all bolts and screws are tight.

**What attention do****Ball Bearings require?**

The ball bearings used in the Tractor will last indefinitely if they are kept well lubricated and free from grit. When the Tractor is being overhauled or repaired the ball races

**Answer No. 113****Answer No. 114**

should be cleaned with kerosene and examined carefully. If any chipping of the balls or pitting of the races is found, the bearings should be replaced by a new one. It is impossible to replace a broken ball.

Be careful that all bearings are replaced with the stamped face of the outer ring in the correct position. (See Plate No. 26.)

**What should be done when the Tractor is stored?****Answer No. 115**

Drain the water from the radiator and then put in about a quart of denatured alcohol to prevent freezing of any water that may possibly remain. Drain the water from the air washer. Drain off the kerosene and gasoline. Drain off the dirty oil from the crank case and refill with fresh oil, crank the motor enough so that the different parts get covered with oil. Cover the Tractor with the Tractor cover and store in a dry place.

**Summary of Motor Troubles and Their Causes****(a) MOTOR FAILS TO START**

1. Gas mixture too lean or poor grade of gasoline.
2. Water in fuel.
3. Vibrators adjusted too closely.
4. Water or congealed oil in commutator.
5. Magneto contact point obstructed with foreign matter.
6. Gasoline supply shut off.
7. Lack of water in air washer.
8. Water frozen in bottom of gasoline tank.
9. Water on spark plugs or wire terminals.

**(b) MOTOR LACKS POWER—RUNS IRREGULARLY**

1. Poor compression on account of leaky valves.
2. Imperfect gas mixture.
3. Spark plugs dirty.
4. Coil vibrator burned or improperly adjusted.
5. Air leak in intake manifold.
6. Weak exhaust valve spring.
7. Too great clearance between valve stem and push rod.
8. Spark plugs dirty or points imperfectly adjusted.
9. Commutator contact imperfect.
10. Burnt out Vapor Tube—See Answer No. 66.

**(c) MOTOR STOPS SUDDENLY**

1. Fuel tank empty.
2. Water in fuel.
3. Dirt in vaporizer or feed pipe.
4. Magneto wire loose at either terminal.
5. Magneto contact point obstructed.
6. Overheated on account of lack of oil or water.
7. Gas mixture too lean.

**(d) MOTOR OVERHEATS**

1. Lack of water.
2. Lack of oil.
3. Fan belt torn, loose or slipping.
4. Carbon deposit in combustion chamber.
5. Spark retarded too far.
6. Gas mixture too rich or too lean.
7. Water circulation retarded by sediment in radiator.
8. Dirty spark plugs.
9. Lack of water in air washer.

**(e) MOTOR KNOCKS**

1. Carbon deposit on piston heads.
2. Loose connecting rod bearings.
3. Loose crank shaft bearings.
4. Loose piston or piston pins.
5. Spark advanced too far.
6. Motor overheated.
7. Gas mixture too rich or too lean.

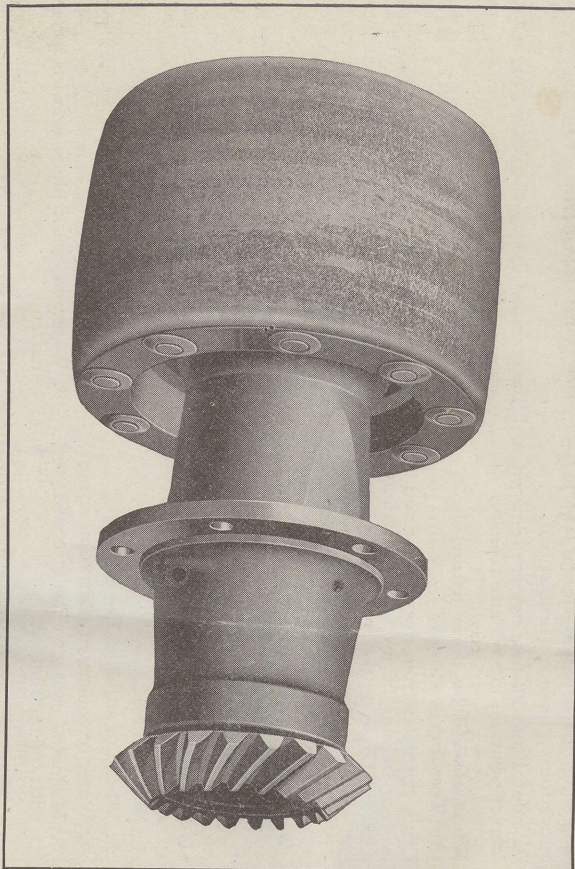

Belt Pulley—Plate No. 39

## Instructions for Installing the "Fordson" Belt Pulley Attachment

1. Place jack under drawbar cap, slightly toward the right hand side. Jack up the tractor sufficiently to remove the right rear wheel, first making sure that the tractor is properly blocked before removing it.
2. Remove foot bracket, part No. S-790 (See Plate No. 1) and satisfy yourself that the tractor is equipped with part No. S-336 Transmission Drive Shaft Spiral Bevel Gear. This is the gear that drives the pulley attachment and must be installed before the pulley can be operated. If you find that this gear is not installed you can procure one (gratis) from your nearest dealer.
3. Install pulley attachment assembly so that one of the holes in the pulley housing is in a downward position, to let the lubricating oil drain back into the transmission.
4. Two paper gaskets, part No. S-791 are provided with each pulley attachment and are to be applied before bolting the pulley housing to the transmission.
5. After tightening up the six cap screws, hold the pulley between the two hands and make sure that there is a slight play or back lash between the two gears, otherwise a grinding noise will be noticed while running which indicates that the gears are too tightly meshed. Operating in this condition will cause the premature wearing of gears and ball bearings in addition to consuming more power than is required. After installing pulley attachment, if the gears are meshed too tightly, a third gasket should be applied. This can be made from ordinary wrapping paper.
6. In cranking the engine after the belt has been applied, see that the clutch pedal is held down or difficulty will be experienced in turning over the motor.

## Specifications—Fordson Tractor

**MOTOR**—Four cylinder, four-cycle, cylinders cast en bloc. Cylinder bore is four inches; piston stroke, five inches. Firing order of cylinders is 1, 2, 4, 3. There are three main bearings two inches in diameter by two inches long. Connecting rod bearings are two inches in diameter by 2 1/4 inches long. Piston displacement, 251.3 cubic inches; piston clearance: top .0150, bottom .0045. Valves have 1/8" lift. Inlet opens 10° past upper dead center with piston 1/4" above top of cylinder; inlet closes 40° past lower dead center with piston 4 1/2" to 4 3/4" below top of cylinder. Exhaust opens 30° ahead of lower dead center with piston 4 1/8" to 4 3/4" below top of cylinder; exhaust closes on upper dead center with piston 1/8" to 1/4" above top of cylinder. Tappet clearance is .007 to .022.

**Lubrication**—Splash system. The oil circulation is maintained by oil thrown off the flywheel by centrifugal action. Capacity 2 1/4 gallons, heavy gas engine oil. Oil temperature when pulling steady maximum load 150° to 200° Fahr. Tractor Lubricating Oil of following specifications to be used both in motor and transmission: Flash Point 400 deg. F. Minimum (Cleveland Open Cup Method); Fire Point 450 deg. F. Minimum (Cleveland Open Cup Method); Viscosity at 100 deg. F. 650 Maximum, Viscosity at 210 deg. F. 66 Minimum (Saybolt Universal Method); Cold 45 deg. F. Maximum (A. S. T. M. Pour Method).

**COOLING**—Thermo-siphon system. The very large water jackets and radiator tanks used with a vertical tube radiator insure a continuous flow of water and efficient cooling. This works in connection with a belt-driven ball bearing fan delivering 1700 cubic feet of air per minute. Water capacity of cooling system, 12 gallons. Cylinder water inlet is 2 3/4" diameter; outlet approximately 4" diameter.

**FUEL**—Supplied by gravity from a 21 gallon overhead tank.

**AIR WASHER**—Float type, 7 quarts capacity. The air supply is drawn through water, which removes all dust, thus reducing wear on cylinder walls.

**TRANSMISSION**—Constant mesh selective type, three speeds forward and one reverse. All shafts run on ball bearings. Clutch—multiple disc, 17 hardened discs running in oil. Lubrica-

tion—capacity 3 3/4 gallons. Oil temperature when pulling steady maximum load, 175° to 250° Fahr. See oil specifications under "Motor Lubrication" above.

**TRANSMISSION GEARS**—Speeds based on 1000 R. P. M. of engine.

Gear	Final Ratio	Worm Speed	Axle Speed	Tractor Speed
Low	81.87	207.7	12.23	1.53 M. P. H.
Intermediate	44.46	382.3	22.49	2.81 M. P. H.
High	17.74	958.3	56.36	6.93 M. P. H.
Reverse	46.39	366.4	21.56	2.69 M. P. H.

**REAR AXLE**—Semi-floating, four-pinion differential running on ball bearings.

**FRONT AXLE**—Drop forged and heat treated. It is attached in the center directly to the front of the motor, giving a three-point suspension to the tractor.

**WHEELS**—Front wheels have steel spokes cast in the hub and riveted to rim; they are mounted on adjustable roller bearings. Rear wheels have spokes cast in the hub and riveted to the rim.

**WEIGHTS**—Weight of tractor less driver, water, oil and lugs, 2425 pounds. Total weight of tractor, including all liquid supplies and 150 pound driver, 2920 pounds. Distribution of weight above weight: front wheels, 1063 pounds; rear wheels, 1857 pounds. Weight of engine with vaporizer and coils, 661 pounds.

**DIMENSIONS**—Wheel base 63"; distance between front rims 40 1/8"; distance between rear rims 37 3/8"; width of front rim 5"; diameter of front rim 28"; width of rear rim 12"; width of extension rim 7"; diameter of rear rim 42" (3" clears riveted on rim); overall length of tractor, 102". Overall width of tractor 61 3/8"; overall height of tractor 54 3/8"; ground clearance 11 3/8"; height of draw bar from ground 12"; adjustment—lateral, 7"; vertical, none.

**BELT PULLEY**—Width 6 1/2", diameter 9 1/2". Gears, spiral bevel type. Speed, 1000 R. P. M. Belt speed 2480 feet per minute.

**PERFORMANCE**—Size of thresher 20" x 36"; plows, 2-14". Average work, six acres in 10 hours. Turning circle, 21 feet.

# Index

	Page		Page
<b>AIR WASHER</b>			
Attention	25		
Its Purpose	25		
How it Works	25		
<b>BELT PULLEY</b>			
Belt Pulley	54		
<b>CLUTCH</b>			
How Controlled	41		
Its Purpose	41		
How Removed	42		
How it Works	41		
<b>MOTOR</b>			
Carbon—How Removed	17		
Connecting Rod and Bearings	19		
Cylinder Head—How Removed	17		
Motor Fails to Start	53		
Motor Lacks Power—Runs Irregularly	53		
Motor Stops Suddenly	53		
Motor Overheats	53		
Motor Knocks	53		
Knocking—Causes	17		
Main Bearings—How Adjusted	19		
Piston	12		
Removing Power Plant	19		
Replacing Gaskets	21		
Valves	12		
<b>FUEL SYSTEM</b>			
Vaporizer—How Adjusted	29		
Vaporizer—How Controlled	27		
Vaporizer—Its Purpose	27		
Vaporizer—Trouble	29		
Vaporizer—How it Works	27		
<b>IGNITION SYSTEM</b>			
Coils	31		
Communtator	33		
Magneto	31		
Magneto Trouble	35		
Spark Plugs	33		
When to Look for Trouble	33		
<b>LUBRICATING SYSTEM</b>			
Attention Required	51		
Motor	51		
Transmission and Rear Axle	52		
<b>MAINTENANCE</b>			
Cleaning	52		
Storing	53		
Care of Ball Bearings	52		
<b>OPERATION</b>			
Adjustments	11		
Cranking	5		
Fuel	4		
Getting Ready to Start	4		
Gear Changing	9		
Oiling	4		
Radiator	4		
Spark—How Controlled	9		
Speed—How Controlled	11		
Starting	5		
Starting in Cold Weather	8		
<b>REAR AXLE</b>			
Differential	43		
Rear Axle—How to Remove	43		
Wheels—How to Remove	43		
<b>RUNNING GEAR</b>			
Adjustments—Steering Gear	51		
Removing Front Axle	48		
Removing Front Wheel	48		
<b>TRANSMISSION</b>			
Its Purpose	36		
How Removed	39		
How it Works	36		
Gear Shifter—How it Works	36		

**Fordson**  
TRADE MARK

**TRACTOR  
MANUAL**

**Ford Motor Company**  
Detroit, Michigan